

TS-820S BLOCK DIAGRAM

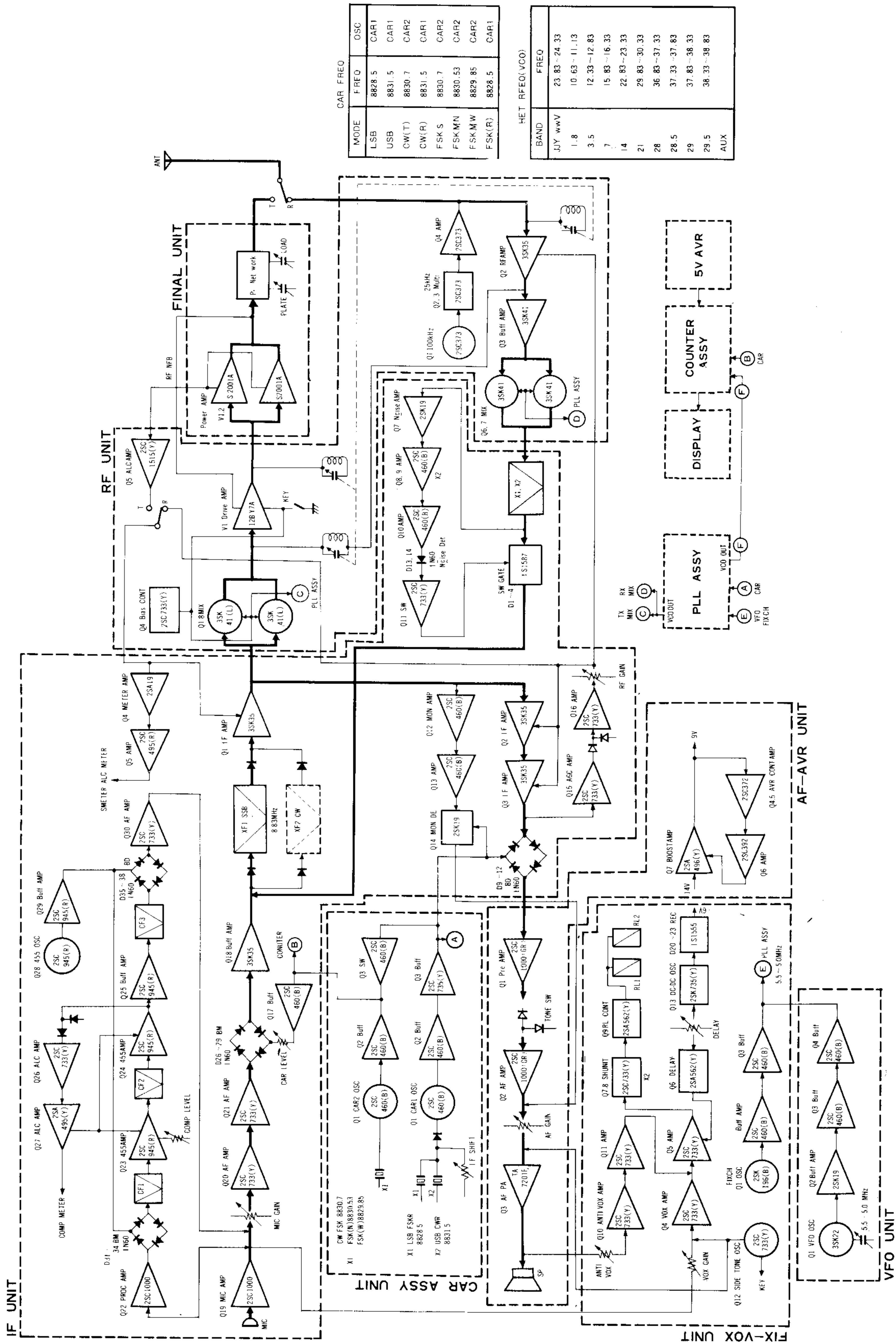

SECTION 5. CIRCUIT DESCRIPTION

5.1 BLOCK DIAGRAM

GENERAL

The block diagram of TS-820S is shown on page 24.

The transceiver is composed of the single superheterodyne receiver and the single conversion type transmitter with a filter type SSB generator. It uses 8,830 kHz IF and its local oscillator is equipped with a PLL (phase locked loop) circuit controlled by VFO. Both the receiver and transmitter use balanced type mixer circuits with dual gate MOS FET's, thus minimizing spurious during transmission and preventing the effects of strong signals and spurious signals during reception.

Taking full advantage of PLL system, the transceiver offers IF SHIFT function (electronic system pass band tuning) and permit one SSB filter to provide the same effect obtained by USB and LSB filters. The transceiver also includes a number of latest accessory circuits such as the RF speech processor, the digital display circuit, transmit monitor circuit, etc.

TRANSMITTER SECTION

The microphone signal is fed to the IF unit, amplified by the microphone amplifier and is then fed to the ring modulator composed of 4 diodes. The DSB output from the modulator passes through buffer amplifier and the crystal filter. The SSB signal thus obtained is further amplified and fed to the transmit mixer of the RF unit.

The transmit mixer is a double balanced type mixer with 2 MOS FETs. The local oscillator is VCO type (voltage controlled oscillator) whose output is controlled by the PLL circuit to minimize spurious during transmission. The SSB signal converted into the wanted transmit frequency is amplified by the transmit driver tube (12BY7A) before being fed to the two S2001A power amplifier tubes of the final stage.

They operate in class AB 1 because of low distortion amplification for SSB signal.

The output signal is transmitted through a pi-network to the antenna.

RF NFB is applied from the output of final stage to the driver stage to further reduce the cross modulation distortion.

RECEIVER SECTION

The antenna signal passes through the RF ATT switch, where it is attenuated by about 20 dB as necessary, and is then amplified by the RF unit.

The amplified signal is fed to the buffer amplifier and mixed with VCO output in the balanced mixer with 2 MOS FETs to produce 8,830 kHz IF signal.

This signal is fed to the IF unit, passes through the noise blanker circuit and the crystal filter, and is finally amplified by the 3-stage IF amplifier, so that it is converted into AF signal by the ring detector.

The AF signal is applied to the AF-AVR unit where it is amplified to the level to drive the speaker. The frequency characteristic of the AF amplifier is automatically changed to suit CW or SSB operation by means of the MODE switch.

5.2 BOARD AND UNIT

IF BOARD (X48-1150-00)

The IF Board is very important for operation of transmitter

and receiver. It is composed of the microphone amplifier, ring modulator, crystal filter, transmit-receive IF amplifier and the noise blanker circuit, AGC amplifier, S meter amplifier, speech processor and mo-

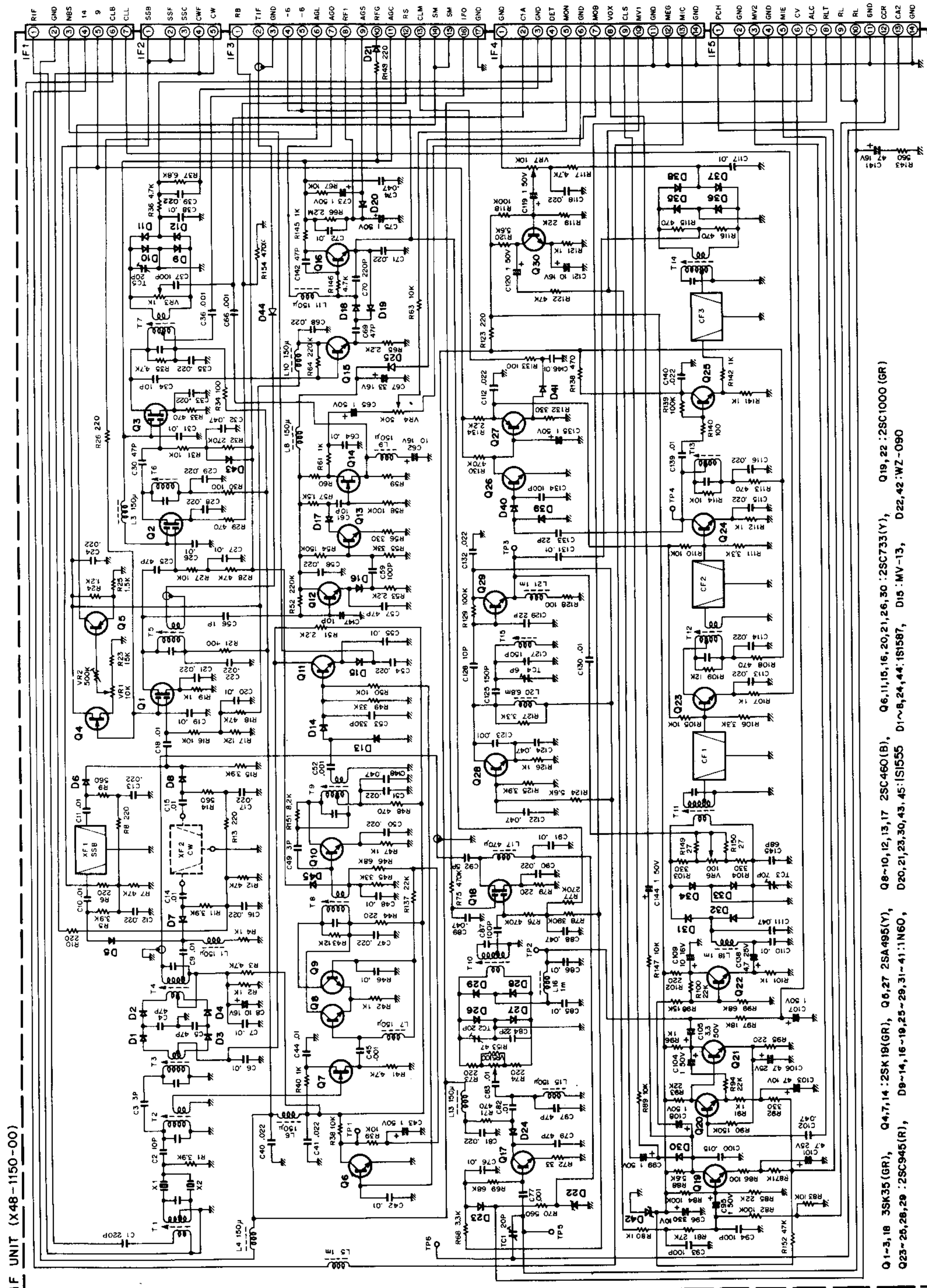

Fig. 12 IF Board

nitor circuit.

Crystal filters are self contained for SSB operation. CW filters (YG-88C) are available as optional accessories, for easy installation.

RF BOARD (X44-1150-00)

The RF Board holds the ALC amplifier circuit and the block bias circuit as well as the RF amplifier and mixer circuit for transmission and reception.

It also includes a coil pack unit for the tuning circuit.

COIL PACK BOARD (X44-1140-00)

Tuning coils for the individual bands and stages, band select rotary switch and variable capacitor are all arranged rationally in one unit. These parts function together with the RF Board.

VFO UNIT (X40-1110-00)

The PLL circuit is controlled by VFO signals, thus the frequency stability of TS-820S is virtually determined by the stability of VFO. The unit is composed of 2 FETs, 2 transistors and 3 diodes. Its oscillation frequency is set to 5.0 ~ 5.5 MHz.

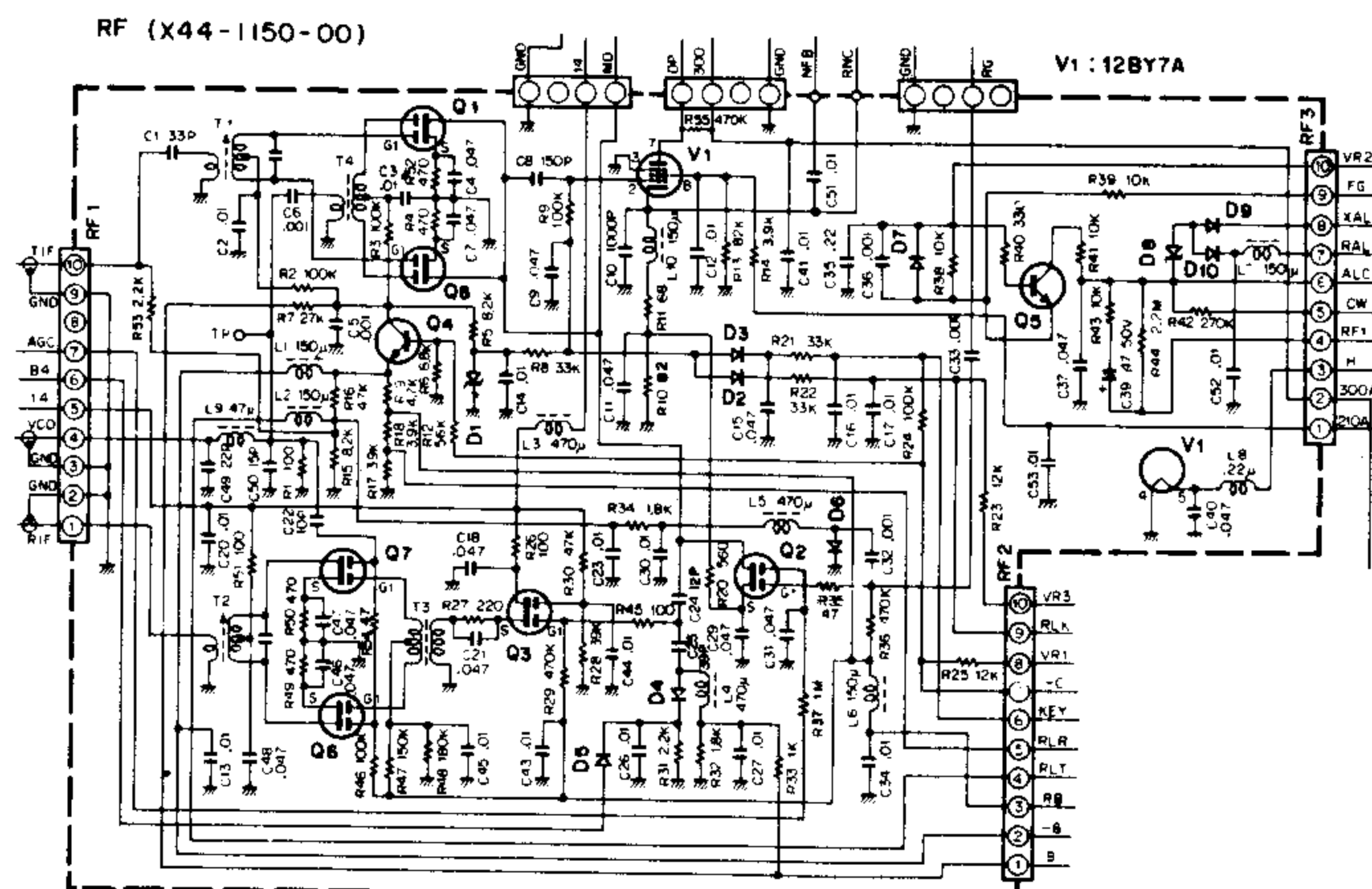

Fig. 13 RF Board

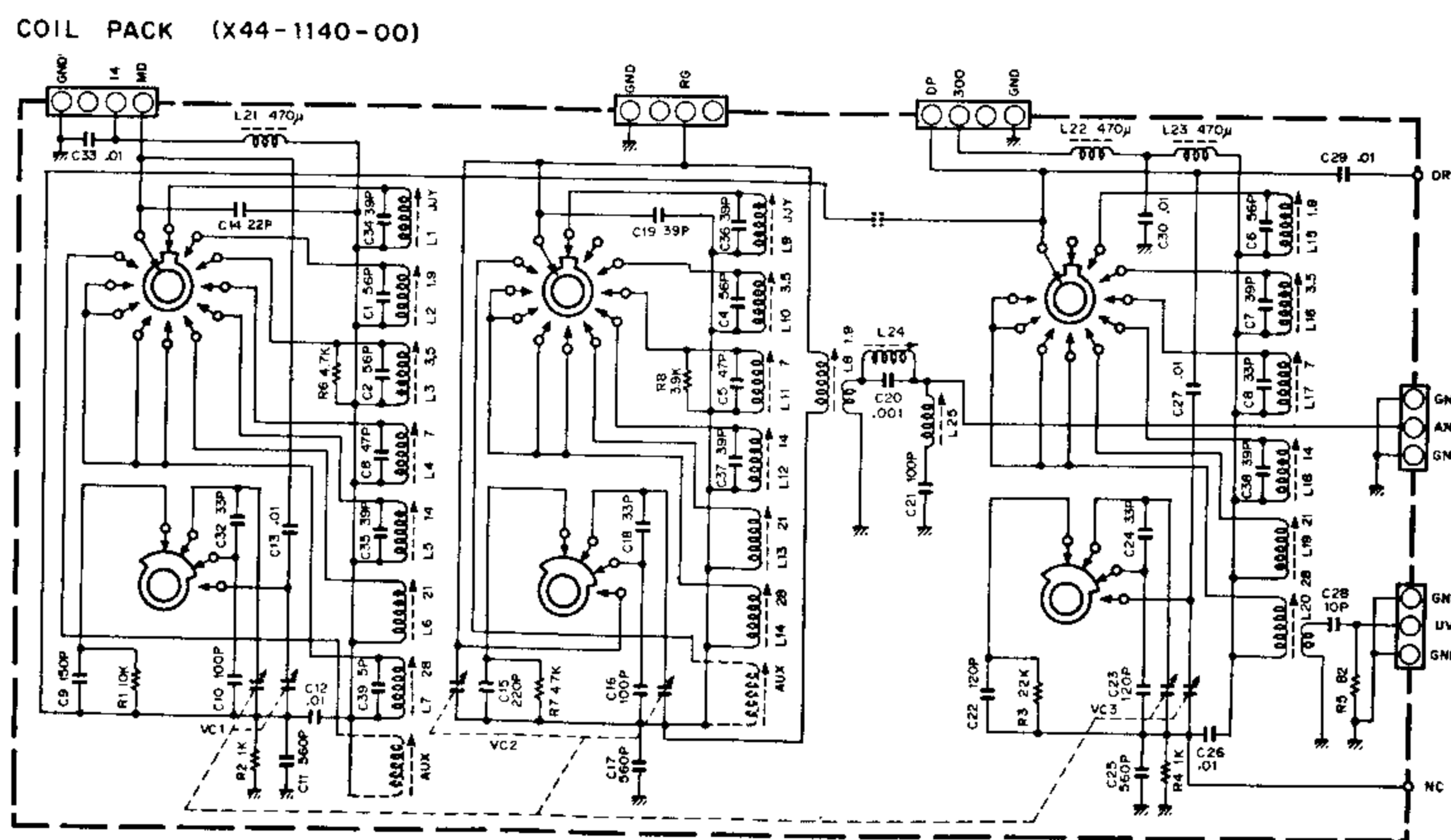

Fig. 14 Coil Pack Board

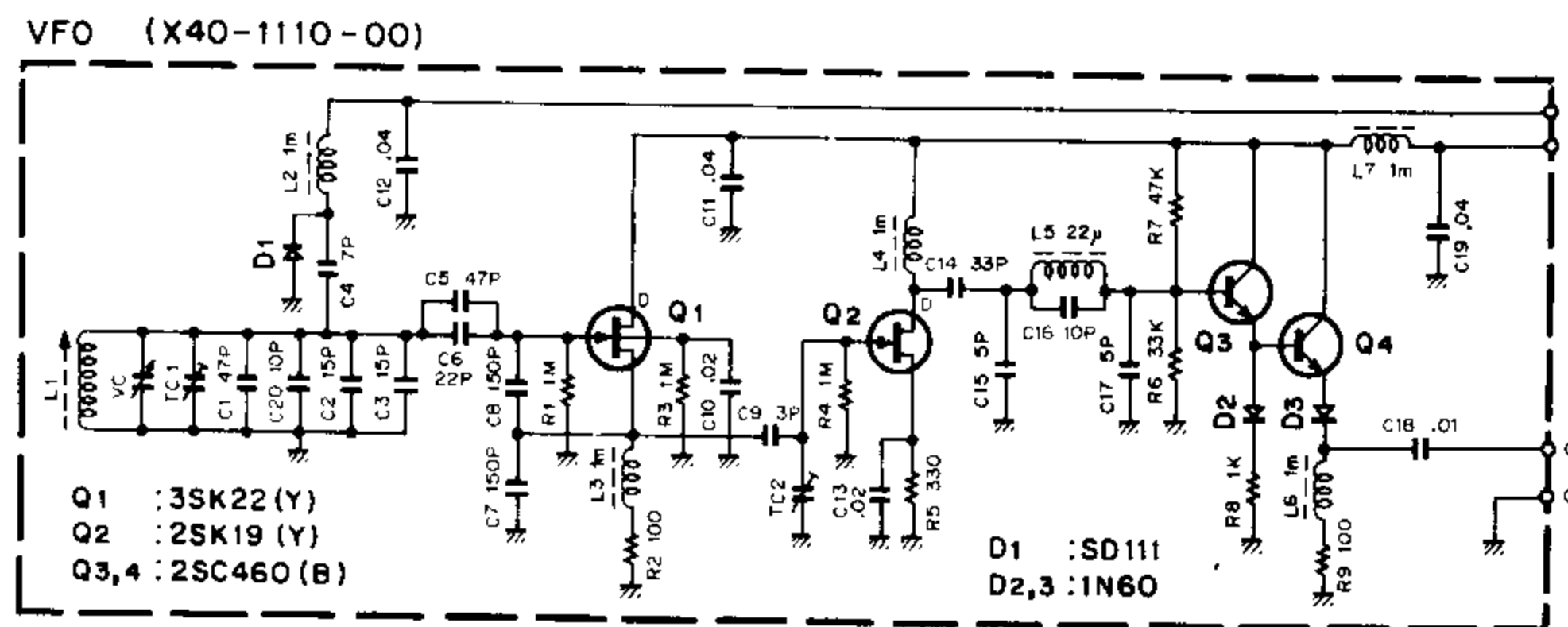

Fig. 15 VFO Unit

PLL Unit (X60-1010-00)

This unit is composed of the PD Board and the VCO Board to function as a local oscillator for the transmitter and the receiver. Stabilized oscillator output like that of the built-in

VFO can be obtained for each band. The PD Board holds crystal oscillators for each band, 2 mixer circuits, waveform shaping circuit and phase comparator. It uses VFO as a

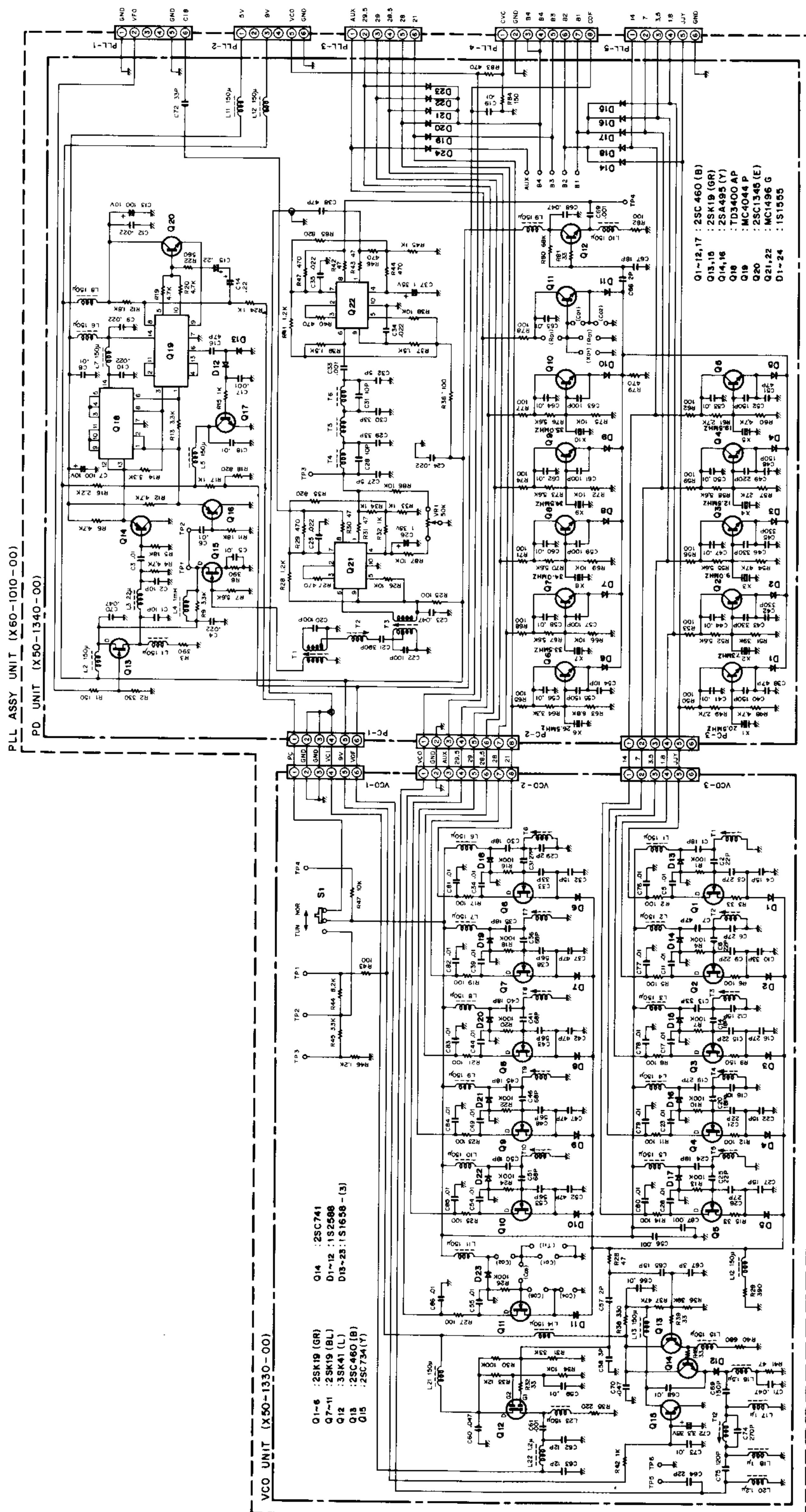

Fig. 16 PLL Unit

standard oscillator to produce a voltage to control VCO (voltage controlled oscillator). It also forms a full electronic IF shift loop using an external carrier signal. The VCO unit is composed of FET type oscillators for each band, buffer amplifier circuit, and the oscillator shut off circuit at the time of fault of the PLL circuit. The oscillator frequency is controlled by the control voltage from the PD Board. The bands of both units can be selected by means of the diode switches.

COUNTER ASS'Y UNIT (X60-1020-00) (TS-820S TYPE ONLY)

This unit is composed of the counter mixer board that produces operating frequencies by mixing the VCO output (local oscillator signal for the mixer) with carrier signal, and the counter board that counts the frequencies in digits. These units are housed in a rigid shielding case. Since the frequencies are read by synthesizing all the local oscillator signals, accurate operating frequencies are always counted under any operating conditions. The counter output is picked up as a signal to drive the indicating tubes and is fed to the display unit.

Counter Ass'y Unit

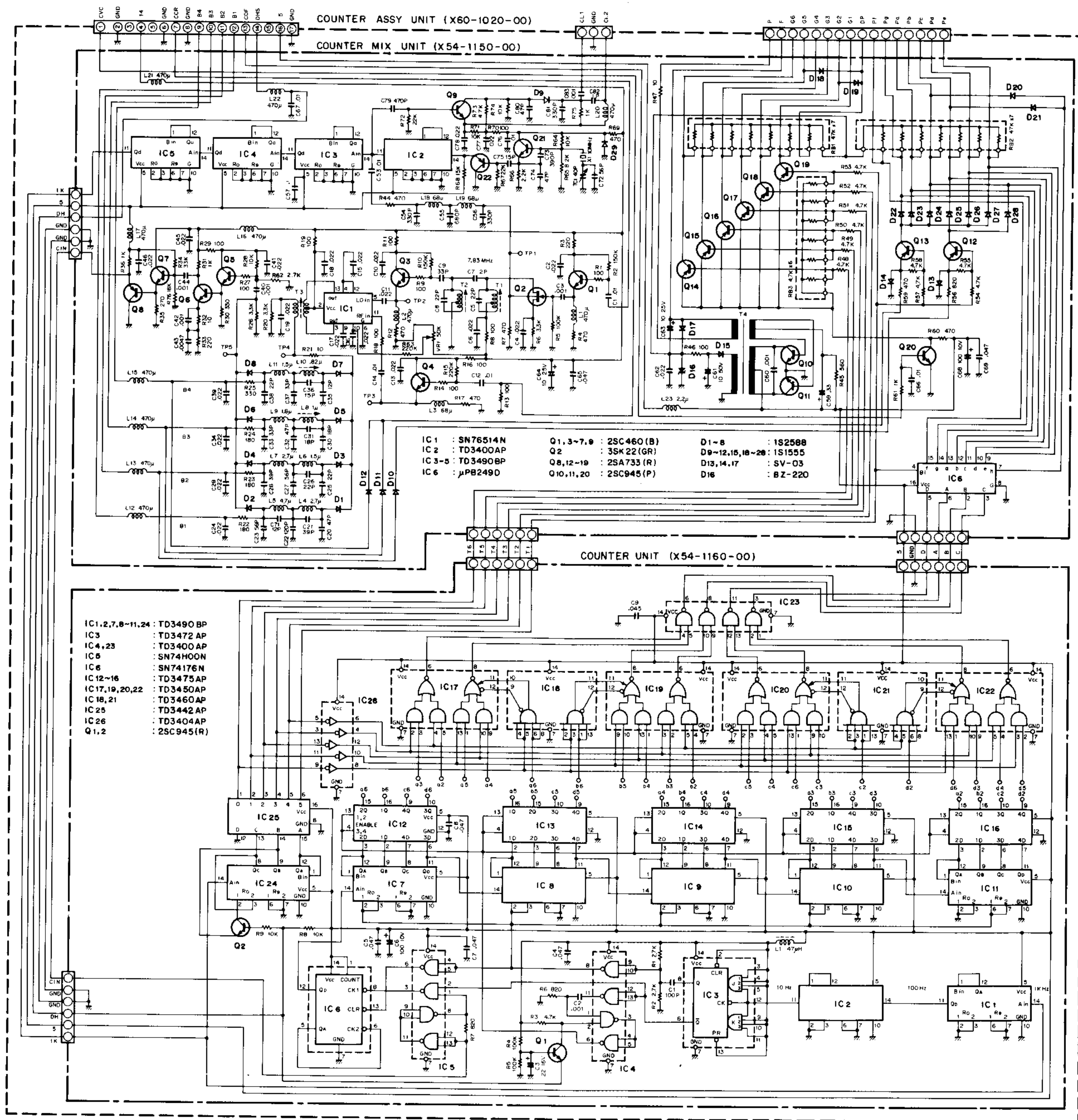

Fig. 17 Counter Ass'y Unit

DISPLAY UNIT (X54-1170-00) (TS-820S TYPE ONLY)

This unit uses a 6 digit fluorescent indicator to indicate operating frequencies counted by the counter unit. All the digits glow green to provide many hours of fatigueless operation.

CAR ASSY UNIT (X60-1000-00)

This is a crystal oscillator that functions as a carrier for the generator during transmission and as a BFO for ring detection during reception. The output is partly applied to the PLL Unit and the COUNTER UNIT.

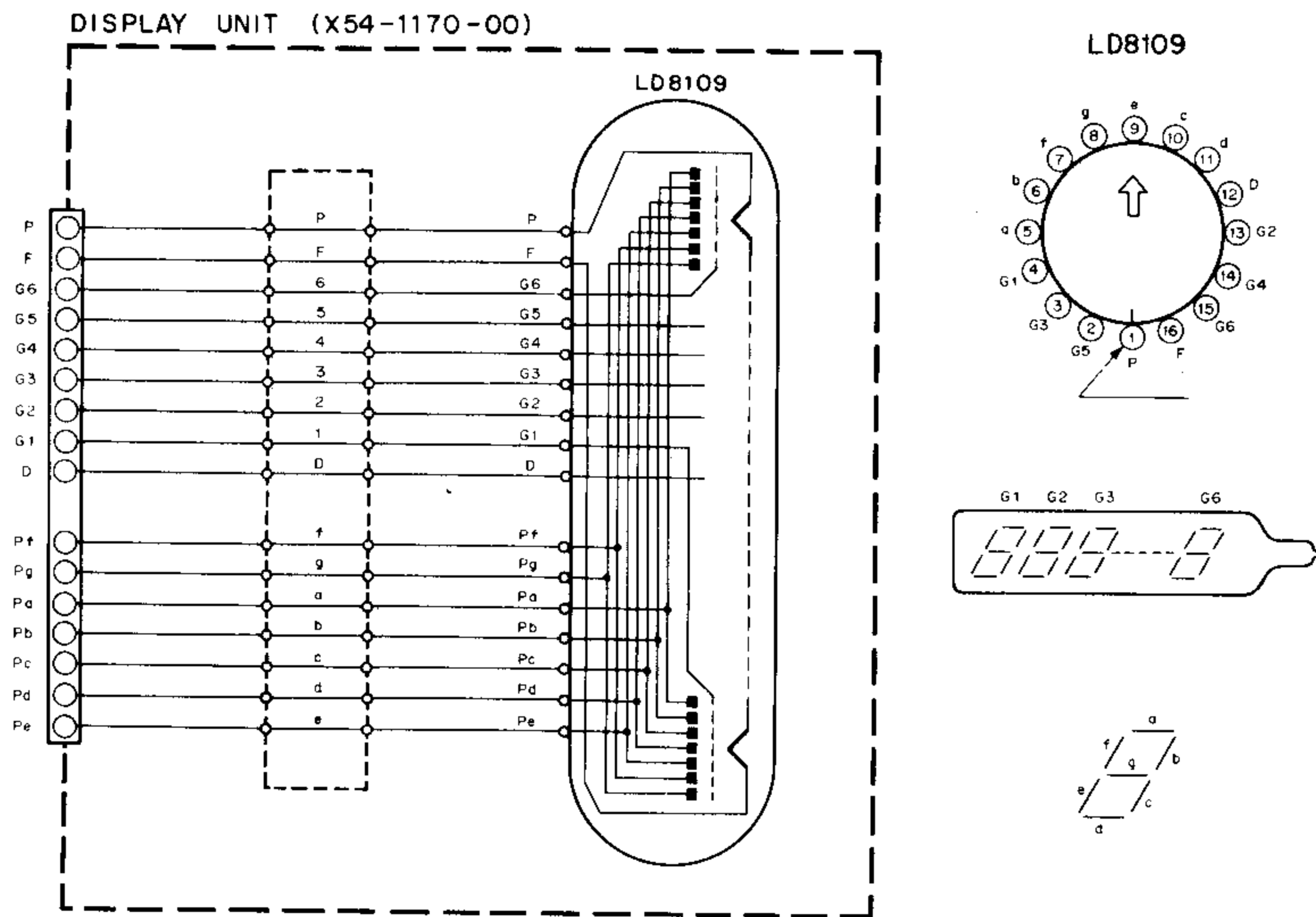

Fig. 18 Display Unit

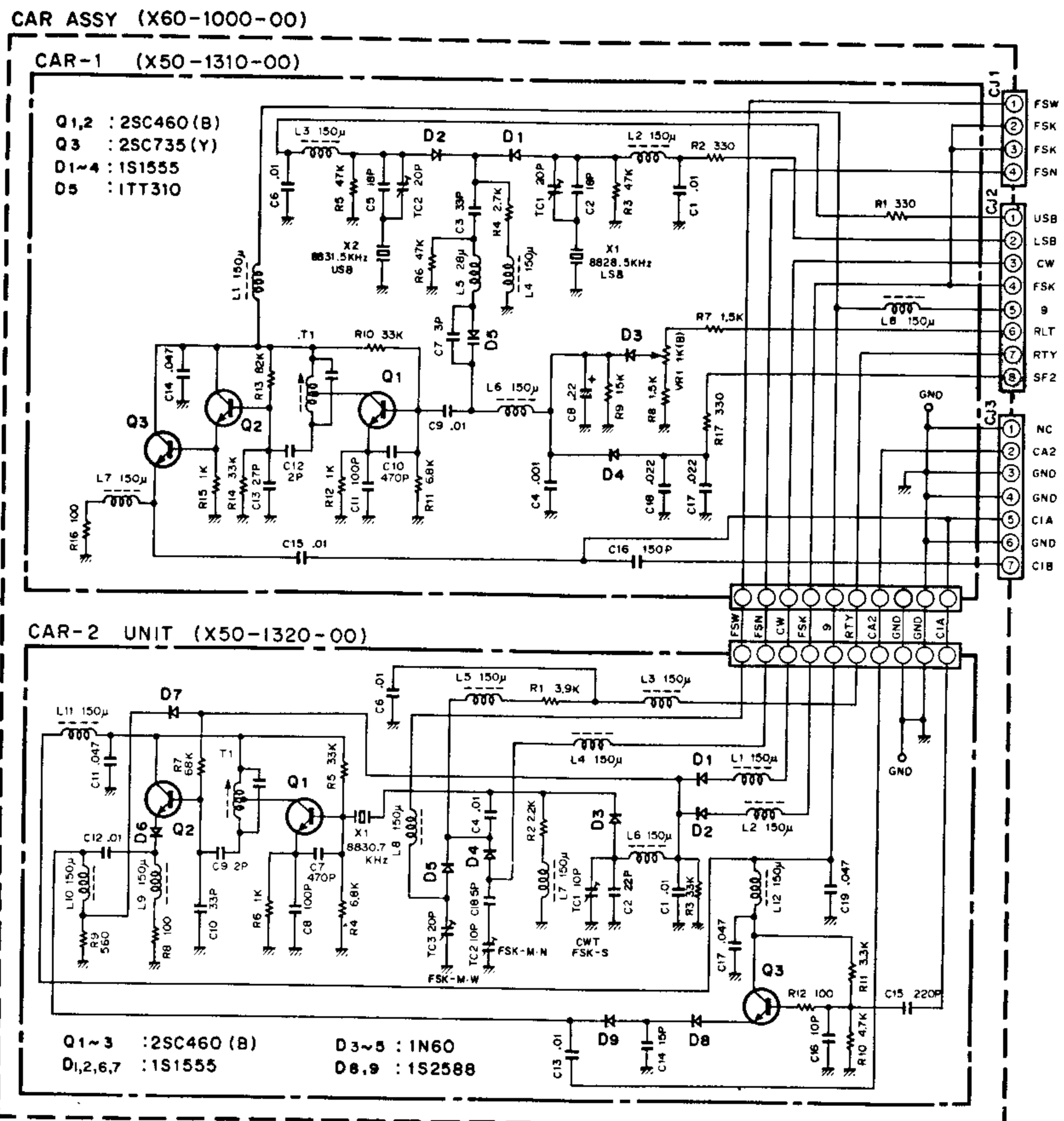

Fig. 19 CAR UNIT

AF-AVR BOARD (X49-1080-00)

This Board represents the final stage of the receiver circuit, holding an AF amplifier and a 9V power stabilizer. The frequency characteristic of the AF amplifier can be varied for CW and SSB operation.

FIX-VOX BOARD (X50-1350-00)

This Board incorporates the fixed channel oscillator, the VOX (voice control) circuit controls voice operated transmission, the side tone oscillator to monitor CW signals and the voltage generator circuit for the block bias circuit (-6V).

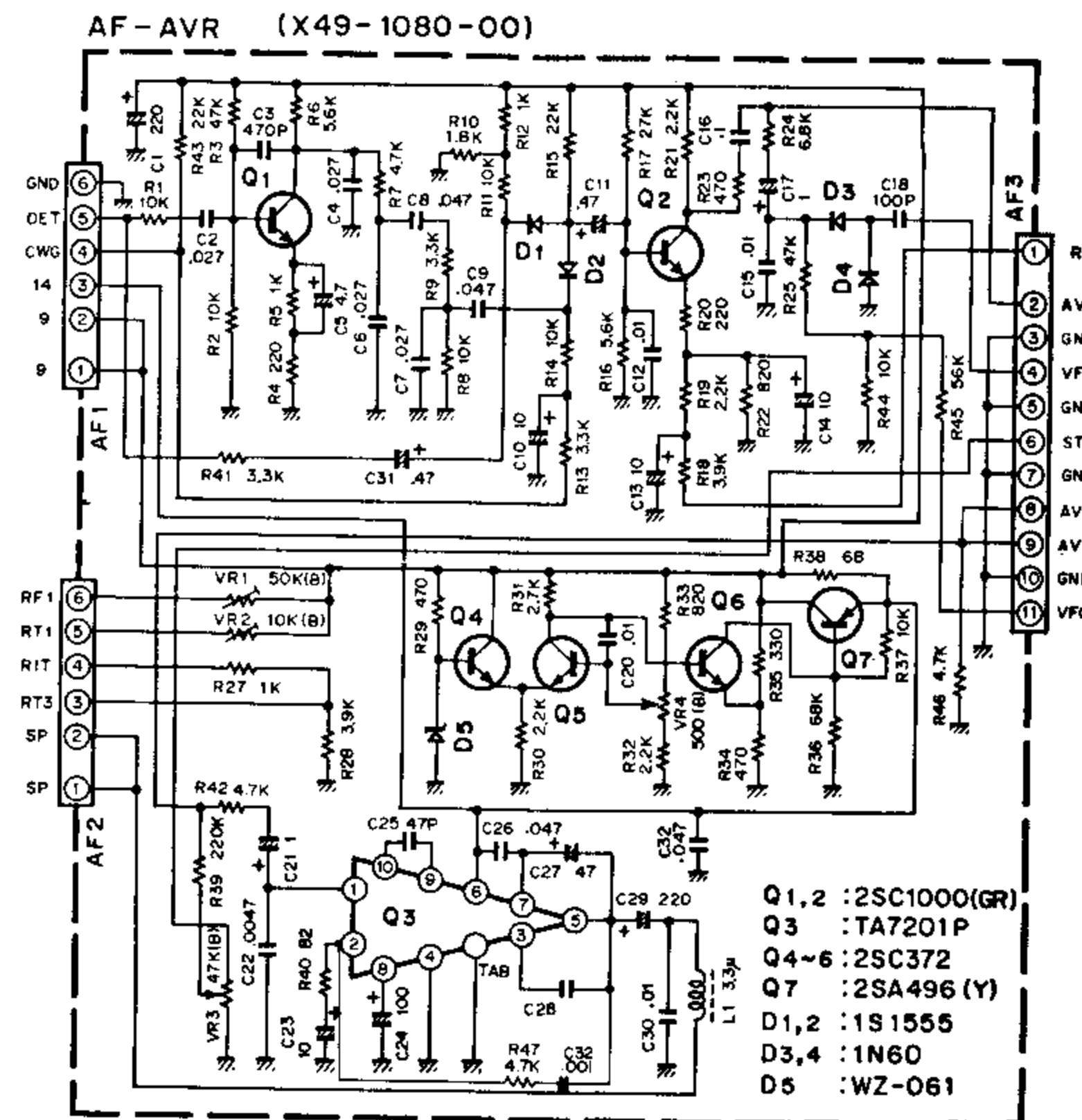

Fig. 20 AF-AVR Board

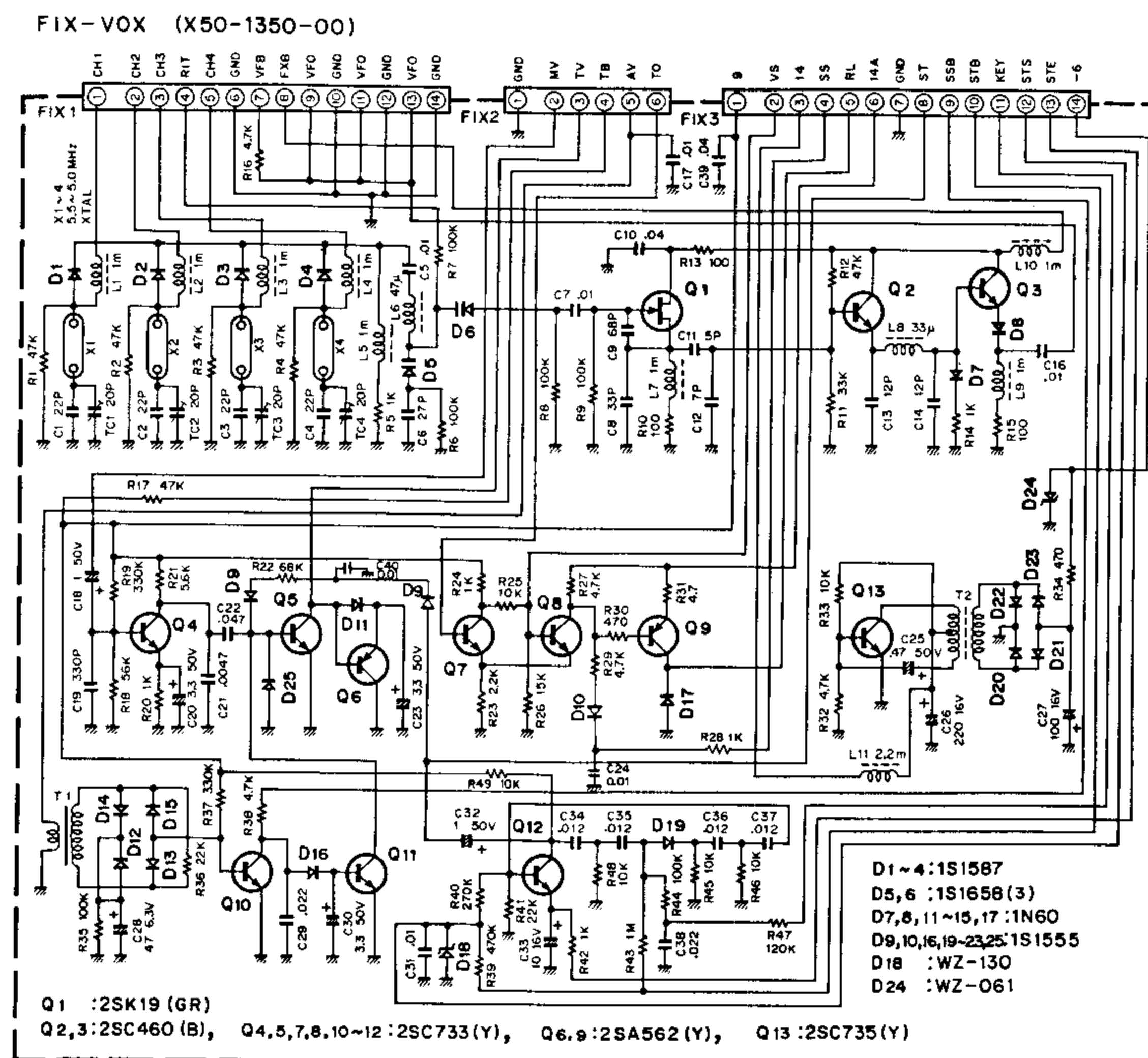

Fig. 21 FIX-VOX Board

VOX-VR BOARD (X54-1190-00)

Three variable resistors, VOX GAIN, ANTI VOX and DELAY, are directly mounted on a printed circuit board.

5V AVR BOARD (OPTION) (X43-1220-00)

This is a 5V power stabilizer used for the counter unit. It uses IC to provide rated voltage without making any adjustments.

MARKER BOARD (X52-0005-01)

The MARKER board holds the 100 kHz crystal oscillator (Q1) and a 25 kHz multivibrator (Q2 and Q3) to produce marker signals at 25 kHz intervals to calibrate the TS-820. Q4 amplifies the calibrator signal.

RECTIFIER BOARD (X43-1090-02)

This board holds all of the diode rectifiers for the power supply section of the transceiver. D1 through D4 rectify the high voltage, D5 rectifies the 300 volt supply, D6 rectifies the 210 volt supply, D7 rectifies the 90 volt supply, and D8 through D11 rectify the 13.8 VDC supply.

HV (HIGH VOLTAGE) BOARD (X43-1110-00)

This voltage divider circuit supplies a high voltage metering signal for the HV meter reading and also a low voltage screen source used in the TUN mode of operation.

INDICATOR BOARD (X54-1180-00)

This circuit controls the light emitting diodes which indicate when the RIT circuit is on, when the fixed frequency oscillator is operating, or when the VFO is oscillating.

RELAY BOARD (X43-1190-00)

This unit holds the stand-by relay, a 5V power stabilizer to feed power to the PLL circuit, and smoothing capacitors to obtain low voltage DC power.

The relay of this unit is used to select DC signal for controlling block bias, cross channel operation, etc.

FINAL BOARD (X56-1200-00)

This unit includes all the circuits of the power amplifier of the final stage with the exception of the pi-network circuit at the output side.

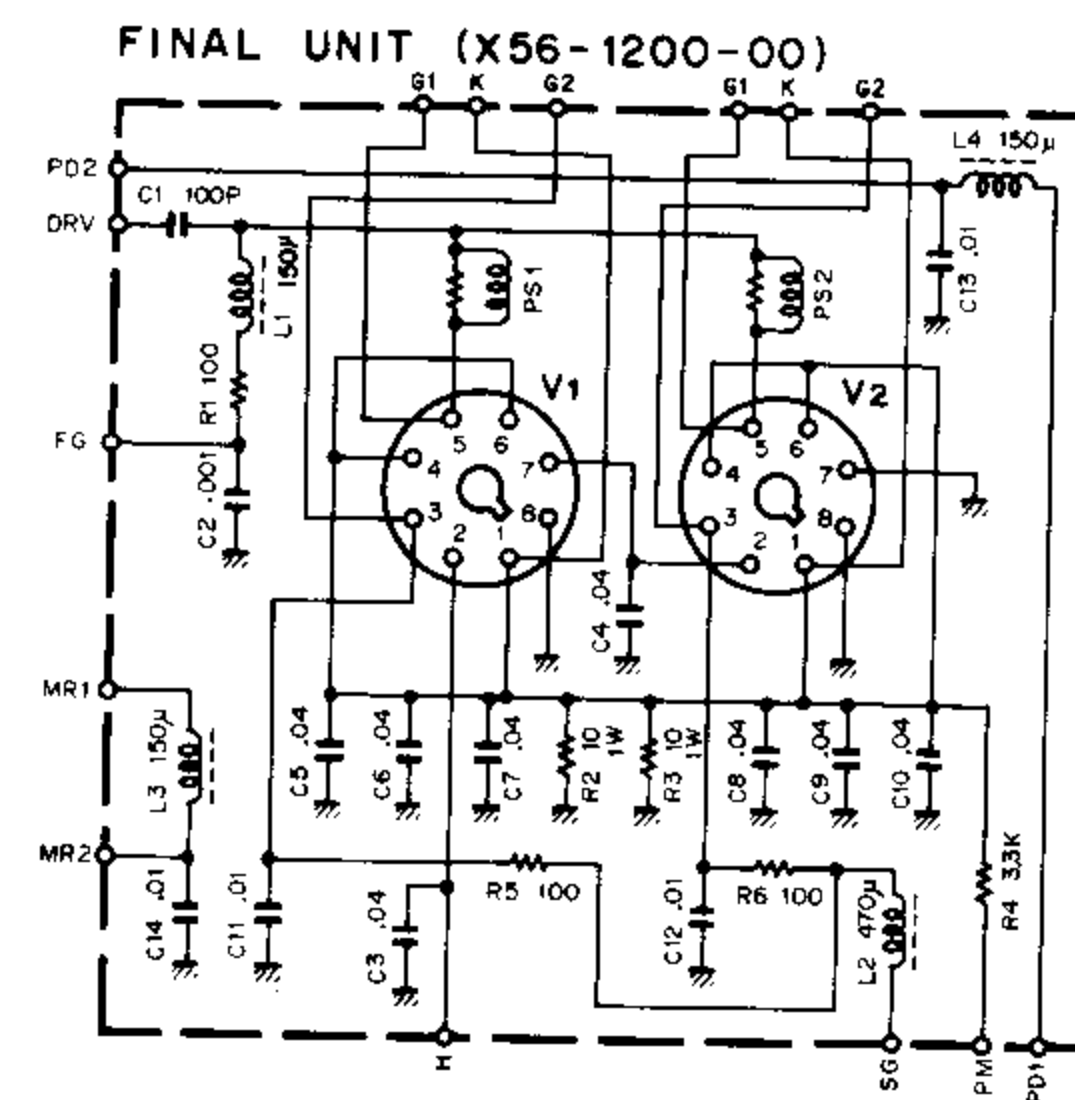
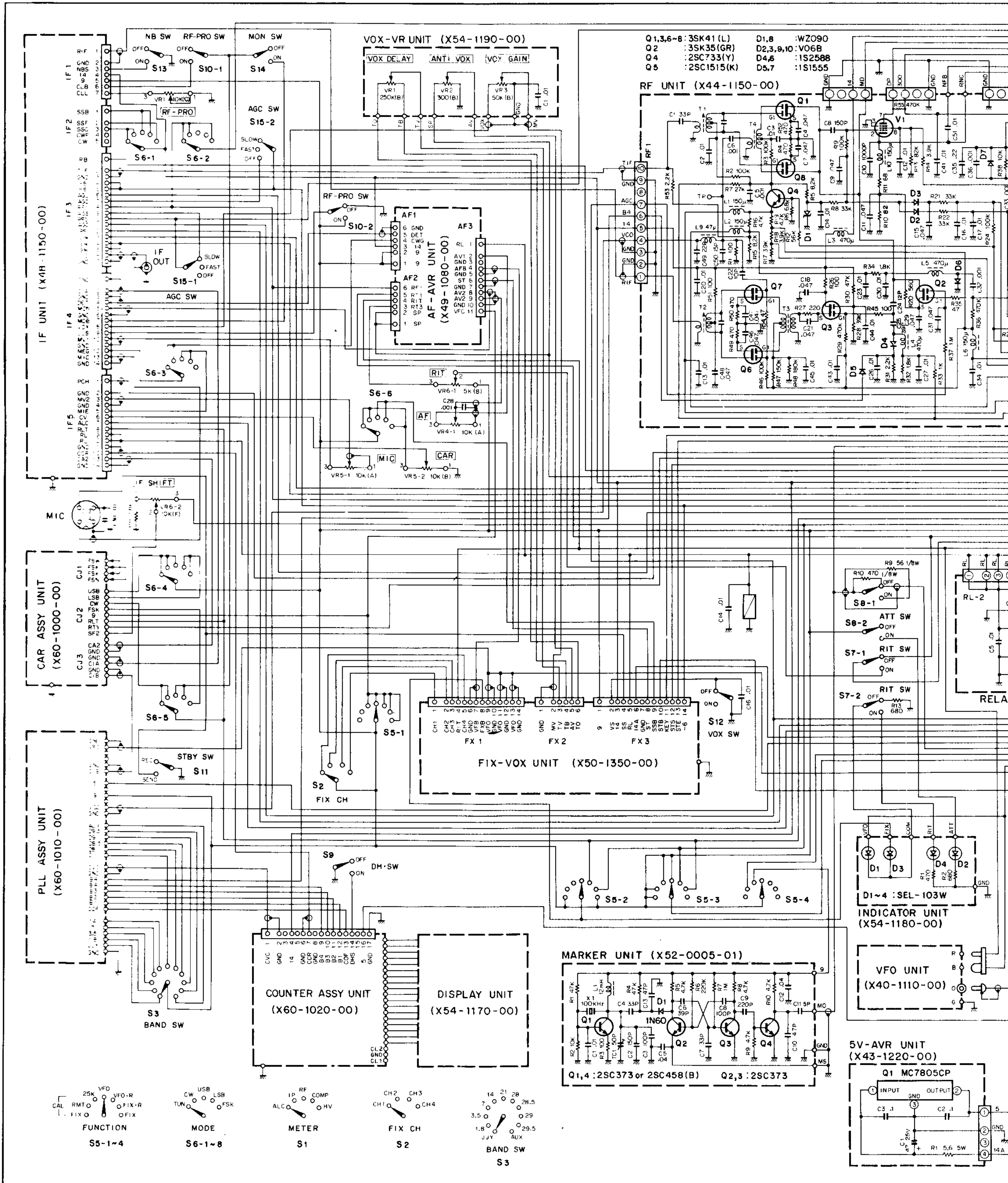

Fig. 22 FINAL Board

5.3 FINAL STAGE POWER AMPLIFIER

This amplifier delivers 200W PEP input by 2 transmit power tubes (S2001A). It is equipped with a cooling fan to avoid temperature rise during operation.

SCHEMATIC DIA



IF UNIT (X44-1150-00)

VOX-VR UNIT (X54-1190-00)

RF UNIT (X44-1150-00)

AF-AVR UNIT (X49-1080-00)

FIX-VOX UNIT (X50-1350-00)

CAR ASSY UNIT (X60-1000-00)

PLL ASSY UNIT (X60-1010-00)

COUNTER ASSY UNIT (X60-1020-00)

DISPLAY UNIT (X54-1170-00)

MARKER UNIT (X52-0005-01)

INDICATOR UNIT (X54-1180-00)

VFO UNIT (X40-1110-00)

5V-AVR UNIT (X43-1220-00)

FUNCTION S5-1~4

MODE S6-1~8

METER S1

FIX CH S2

BAND SW S3

- Q1,3,6-8: 3SK41(L)
- Q2: 3SK35(GR)
- Q4: 2SC733(Y)
- Q5: 2SC1515(K)
- D1,8: WZ090
- D2,3,9,10: V06B
- D4,6: 1S2588
- D5,7: 1S1555

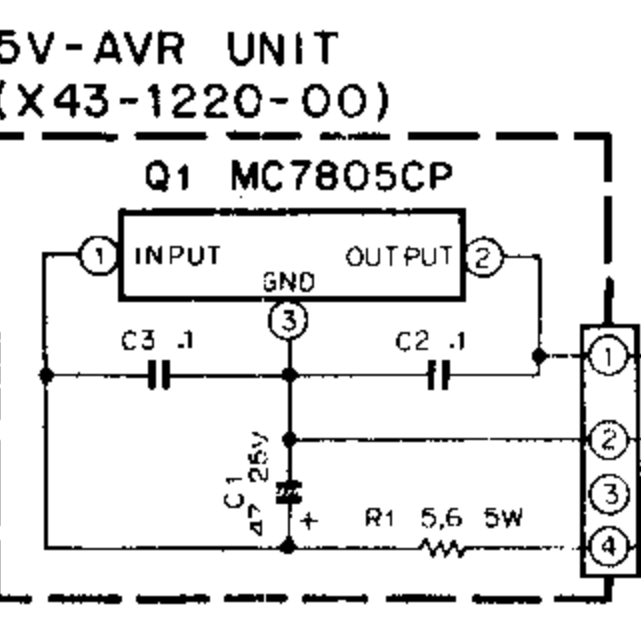

SCHEMATIC DIAGRAM

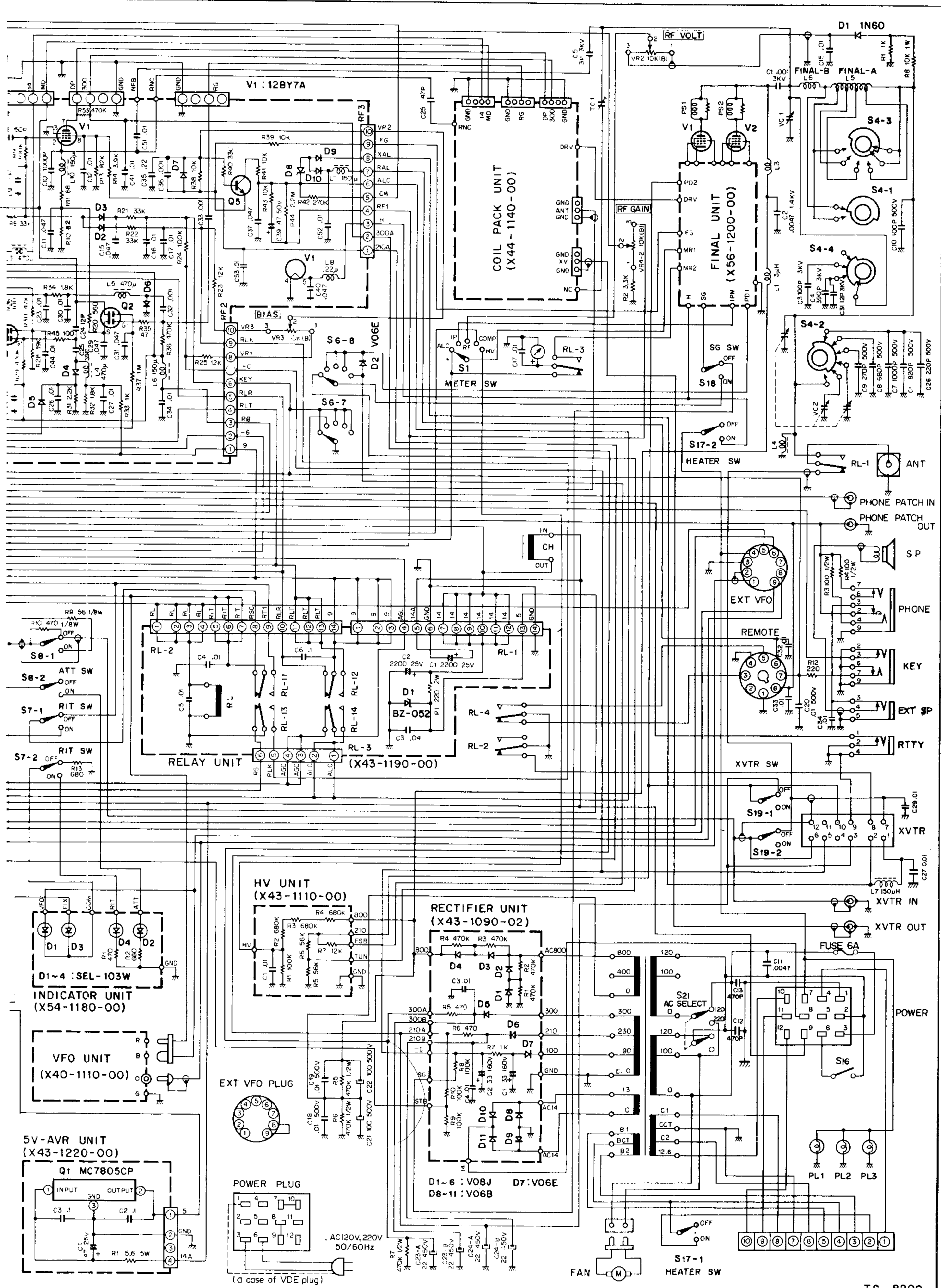

TS-820S

6.4 ADJUSTMENT OF TRANSMITTER SECTION

ADJUSTMENT OF TRANSMIT DRIVE COIL (COIL PACK UNIT)

The drive coil is built in the coil pack unit. Set the SG switch on the rear panel to OFF and the DRIVE knob to its center position. Then, set the METER switch to ALC and the MODE switch to CW or TUN position.

With the standby switch in the SEND position, adjust the drive coils for maximum ALC deflection for each band using the same frequency as for the adjustment of ANT and MIX coils.

During the adjustment, turn the CAR knob just enough to swing the meter (ALC). This adjustment can be started with any band.

ADJUSTMENT OF TRANSMIT IF COIL (IF AND RF UNITS)

Using any frequency, set the transceiver in transmit mode at CW or TUN position. Adjust T5 of the IF unit and T1 of the RF unit until the meter (ALC) indicates maximum deflection.

CARRIER BALANCE ADJUSTMENT (IF UNIT)

(See Fig. 31)

With a dummy load connected to the ANT terminals, adjust for the maximum output using 14.175 MHz frequency. Set the transceiver in LSB mode and turn the RF VOLT knob on the rear panel for maximum sensitivity. The pointer of the RF meter will deflect if the carrier is unbalanced. In this case, be sure to turn the MIC knob to the minimum position. To balance the carrier, adjust the trimmer TC2 and the semi-fixed resistor VR5 alternately until the meter pointer indicates a minimum position. Change the mode to USB and if the pointer deflects, then readjust so that the pointer deflects the same amount for both LSB and USB.

NEUTRALIZING THE FINAL STAGE

Adjust the drive and final stages completely using 21.3 MHz, with a dummy load connected.

Set the SG switch to OFF and measure the output at the ANT terminals (shorted with dummy load) with a high sensitivity RF voltmeter or a tester having a rectifying diode such as 1N60. Then turn the neutralizing variable capacitor (TC1 viewed through the adjusting hole in the upper panel of the final box) for minimum output. Normally, it is unnecessary to remove the shielding case for this adjustment, but be sure to use a insulated screwdriver. Use of a non-insulated screwdriver will result in incorrect adjustment and also cause electric shocks.

ADJUSTMENT OF SIDE TONE LEVEL (AF-AVR UNIT)

Adjust VR3 to your desired level.

ADJUSTMENT OF MONITOR LEVEL (IF UNIT)

Adjust VR4 to your desired level.

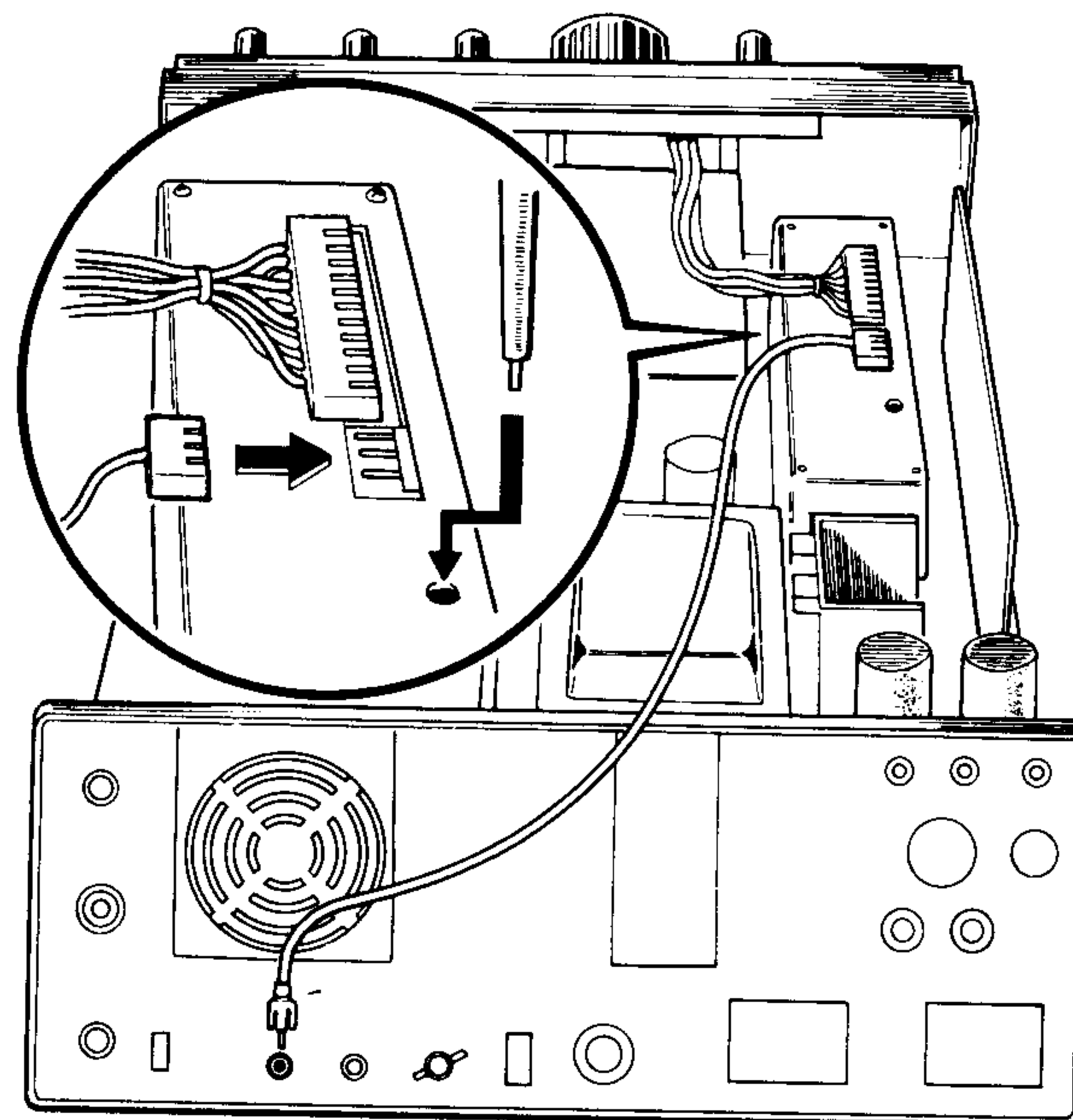

Fig. 31 Counter Frequency Calibration