

 **KENWOOD**

Model TS-660



INSTRUCTION MANUAL

INTRODUCTION

You are the owner of our latest product, the new TS-660 transceiver. Please read this instruction manual carefully before placing your transceiver in service. The unit has been carefully engineered and manufactured to rigid quality standards, and should give you satisfactory and dependable operation for many years.

AFTER UNPACKING:

- Shipping container:
Save the boxes and packing in the event your unit needs to be transported for remote operation, maintenance, or service.
- The following explicit definitions apply in this manual:
Note: If disregarded inconvenience only, no risk of equipment damage or personal injury.
Caution: Equipment damage may occur, but not personal injury.

CONTENTS

SPECIFICATIONS	3
SECTION 1. FEATURES	4
SECTION 2. PREPERATION FOR USE	
2.1 ACCESSORIES	4
2.2 INSTALLATION	4
2.3 INTERCONNECTION	5
SECTION 3. CONTROLS	
3.1 FRONT PANEL.....	7
3.2 REAR PANEL.....	9
SECTION 4. OPERATION	
4.1 RECEPTION	10
4.2 TRANSMISSION	11
4.3 BAND (UP-DOWN) SWITCH	12
4.4 2-VFO OPERATION	12
4.5 F. STEP SWITCH	12
4.6 MEMORY	13
4.7 CW OPERATION.....	13
4.8 MOBILE OPERATION	14
4.9 FIXED STATION OPERATION.....	16
SECTION 5. OPTIONAL ACCESSORIES	17
5.1 OPTIONAL ACCESSORIES	17
5.2 INSTALLING THE OPTIONAL PARTS	18
SECTION 6. ADDITIONAL INFORMATION.....	19
SECTION 7. TROUBLESHOOTING	20
INTERNAL VIEWS	21
BLOCK DIAGRAM.....	22
SCHEMATIC DIAGRAM	23 - 27

TS-660 SPECIFICATIONS

[GENERAL]

Frequency Range:	15 meter band 21.0000 ~ 21.4500 MHz * 12 meter band 24.5000 ~ 24.9999 MHz (Receive only) 10 meter band 28.0000 ~ 29.7000 MHz 6 meter band 50.0000 ~ 53.9000 MHz
Mode:	FM (F3), SSB (A3j), CW (A1), AM (A3)
Frequency Stability: (At room temperature)	Within ± 200 Hz during the first hour after 1 minute of warmup Within ± 30 Hz during any 30 minutes after warmup
Antenna Impedance:	50 Ω
Power Requirements:	12 ~ 16 VDC (13.8 VDC nominal) Transmit (max.) 4 A (SWR: Less than 1.5) Receive 1 A
Semiconductor Complement:	ICs 35 FETs 22 Transistors 156 Diodes 217 Display tube 1
Dimensions (projections excluded):	241 (9-1/2") W \times 94 (3-11/16") H \times 236 (9-5/16") D mm
Weight:	4.9 kg (10.8 lbs)

[TRANSMITTER SECTION]

RF Output Power:	SSB, CW, FM 10 W AM 4 W
Carrier Suppression:	Better than 40 dB
Sideband Suppression:	Better than 50 dB
Spurious Radiation:	21 ~ 28 MHz band Better than 40 dB 50 MHz band Better than 60 dB
Maximum Frequency Deviation (FM):	± 5 kHz
Microphone Impedance:	500 Ω ~ 50 k Ω
Audio Frequency Response:	400 ~ 2600 Hz (-6 dB)

[RECEIVER SECTION]

Sensitivity:	SSB, CW 0.25 μ V for 10 dB S/N AM 1 μ V for 10 dB S/N FM 1 μ V for 30 dB S/N 0.4 μ V for 12 dB SINAD
Image Ratio:	Better than 60 dB
IF Rejection:	Better than 70 dB
Selectivity:	SSB, CW, AM 2.4 kHz (-6 dB), 4.2 kHz (-60 dB) FM 15 kHz (-6 dB), 32 kHz (-60 dB)
	Optional Filter
	AM filter YK-88A 6 kHz (-6 dB), 11 kHz (-60 dB)
	CW filter YK-88C 500 Hz (-6 dB), 1.5 kHz (-60 dB)
	YK-88CN 270 Hz (-6 dB), 1.1 kHz (-60 dB)
Squelch Sensitivity (FM):	0.32 μ V (at threshold)
Audio Output:	1.5 W
Audio Output Impedance:	8 ~ 16 Ω

Note: Circuit and ratings may change without notice due to developments in technology.

* Will transmit on the new 12 meter band. A lead wired for preventing accidental transmission before government amateur authorization.

SECTION 1. FEATURES

1. 21-50 MHz band operation

The transceiver covers 21, 24.5 and 28 MHz HF bands plus 50 MHz VHF band. Band selection is accomplished by UP/DOWN switch. 1 band covers 1 MHz. Operating frequencies can be continuously selectable by a tuning knob.

2. Full variety of operation modes

The transceiver operates in SSB (USB), CW, AM and FM modes.

3. Digital VFO

- * The TS-660 digital VFO is designed so that all frequencies are synthesized by a single crystal oscillator, thereby insuring high stability and excellent accuracy.
- * Equipped with a 10 Hz step digital VFO composed of a triple PLL and 8-bit micro-computer. Optimum frequency step can be selected by MODE and F. STEP switches.
- * Two different VFOs (A and B) are built into the transceiver, allowing cross-channel operation.
- * 5CH memory function stores selected bands and frequencies.
- * Memory SCAN function is also built in. In the SCAN position of the memory selector knob, the transceiver is switched from VFO to memory SCAN mode; the stored channel stops for a given time and then shifts to the next channel.
- * The UP/DOWN switch on the supplied microphone shifts the frequency UP and DOWN.
- * Frequency lock switch is provided. By using the F. LOCK switch, VFO frequency, BAND and microphone UP/DOWN can be locked.

4. Fluorescent display

Frequencies (FM: 5 digits, SSB, CW, AM: 6 digits), VFO A/B and memory CH (1-5) are displayed.

5. IF shift circuit

An IF shift circuit is built into the transceiver to allow shifting the IF passband, thereby eliminating adjacent channel interference.

6. Squelch circuit

A squelch circuit is also built in the transceiver to eliminate noise when signal is absent. It functions on all modes, FM, SSB, AM and CW.

7. CW semi-break-in circuit

Semi-break-in operation is possible in CW mode. Side-tone circuit is also included for CW operation.

8. Two-way antenna connector

The antenna connector is of a 2-terminal type for 21-28 MHz and 50 MHz bands. It can be used, if necessary, as a 1-terminal type (21-50 MHz) by using the select switch on the rear panel.

9. Full variety of indicators

Indicators, RIT, ON AIR, F. STEP and F. LOCK, are neatly arranged on the front panel to facilitate operation.

10. Useful optional accessories

The following accessories are available as optional accessories:

Regulated DC power supply (PS-20), external speaker (SP-120), mobile mount (MB-100), voice controller (VOX-4), CW filter (YK-88C, YK-88CN), AM filter (YK-88A), 3-band (21, 28, 50 MHz) vertical antenna (HA-3), backup AC power supply (BC-1), HF band liner amplifier (TL-120)

SECTION 2. PREPERATION FOR USE

2.1 ACCESSORIES

The following accessories are furnished with the TS-660.

- Microphone with UP-DOWN switch..... 1
- External speaker plug..... 1
- 7P DIN plug 1
- DC power cord 1
- Fuse (4A) 1

2.2 INSTALLATION

It is preferable to choose an operating location that is dry and cool, and to avoid operating the transceiver in direct sunlight.

Allow adequate ventilation, particularly during mobile operation.

2.3 INTERCONNECTION

Connect the transceiver as illustrated in Fig. 2-1.

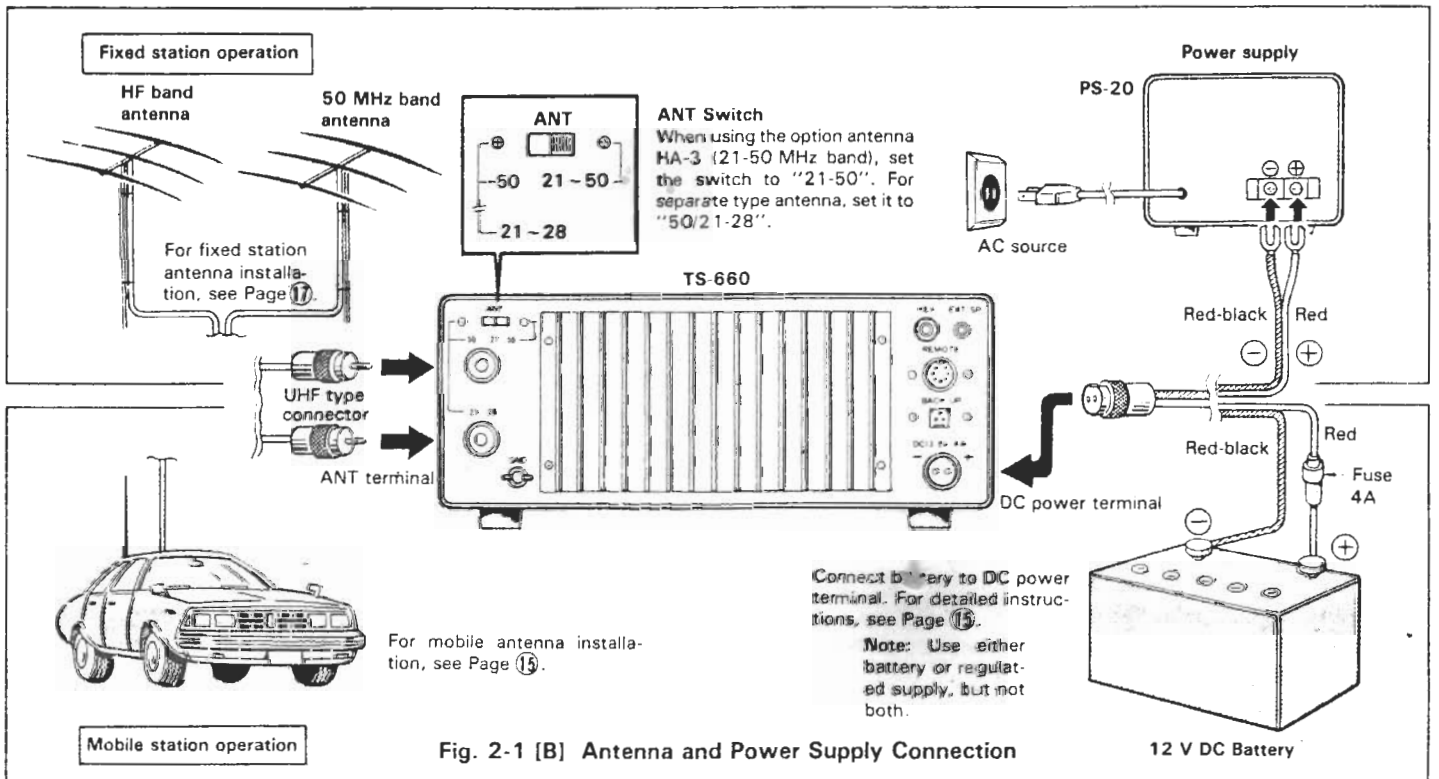
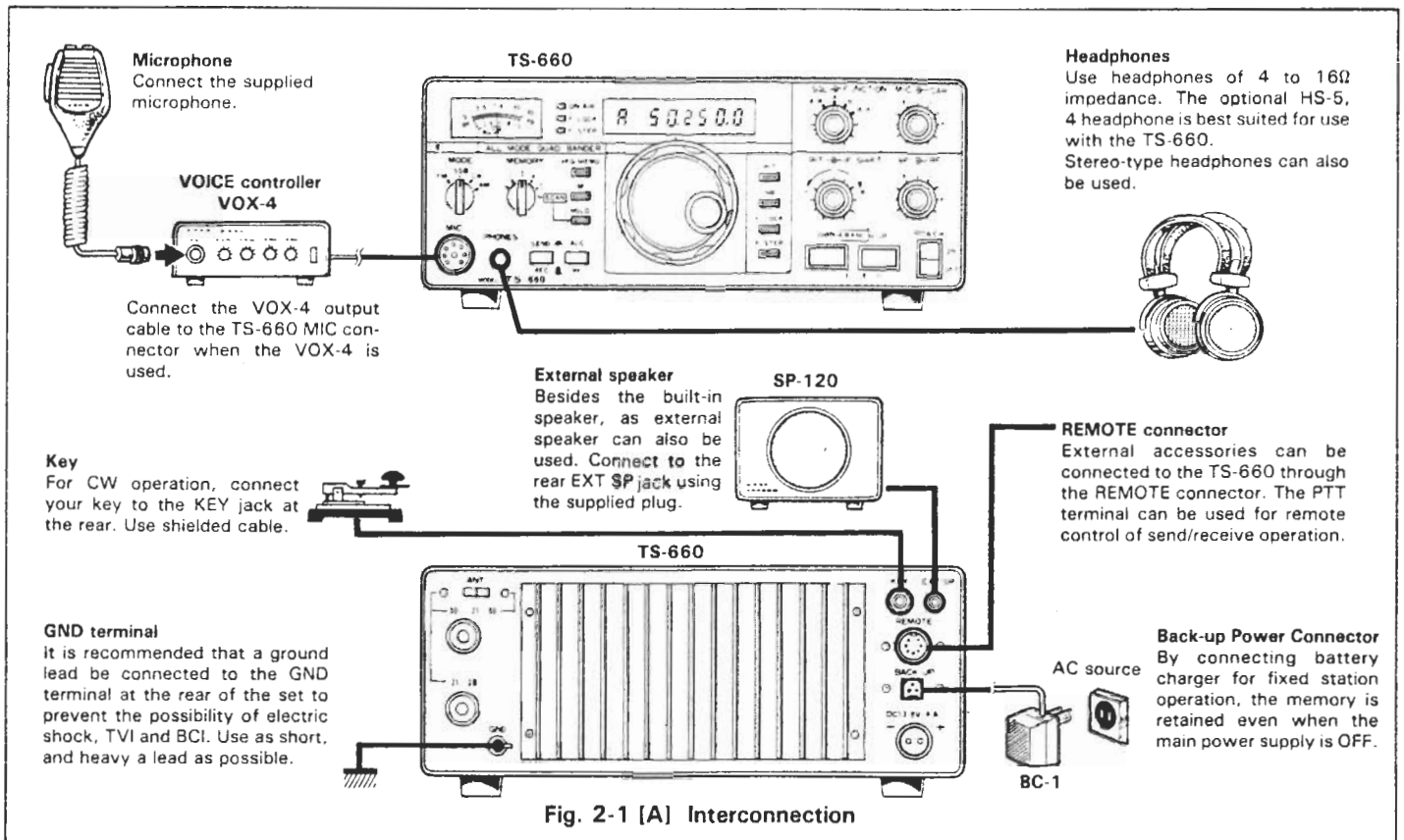

SECTION 3. OPERATION

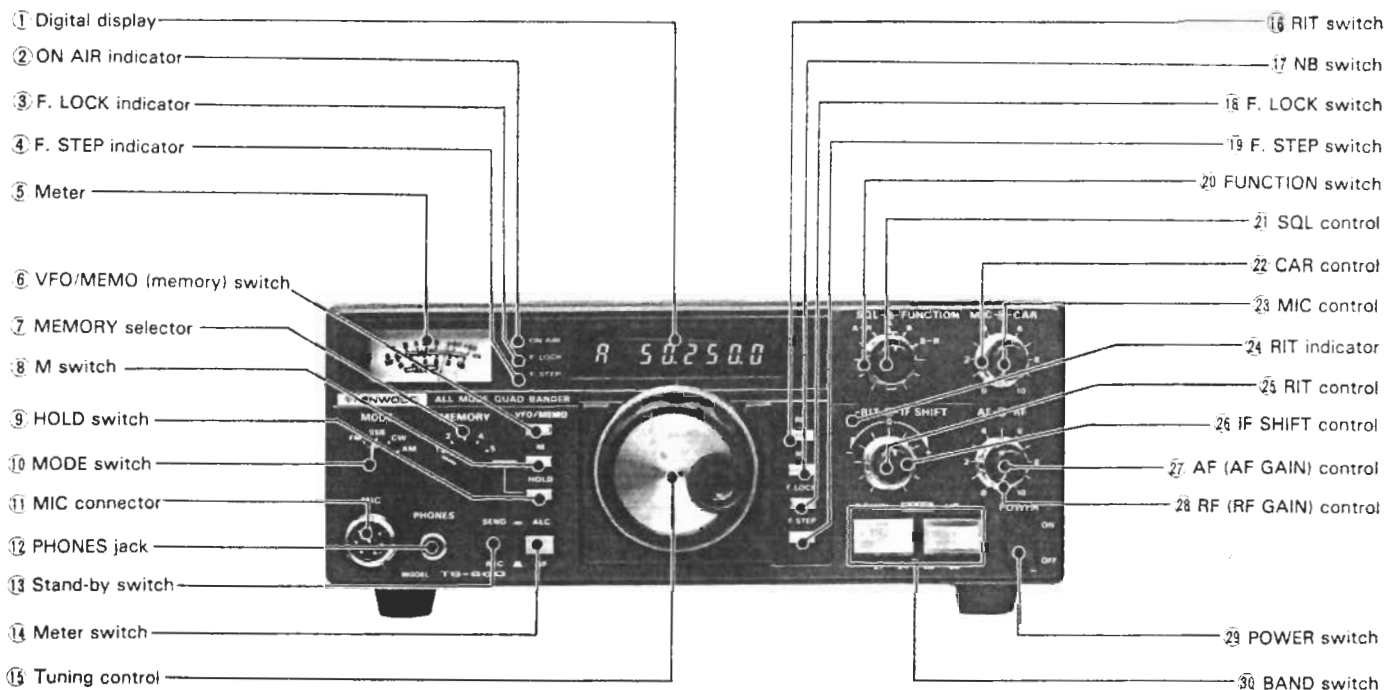

3.1 FRONT PANEL

① Digital Display

The digital display indicates frequencies (FM: MHz-kHz in 5 digits, SSB, CW, AM: MHz-100 Hz in 6 digits), VFO A/B, and memory channels (1-5).

② ON AIR Indicator

This indicator lights when the transceiver is set in transmit mode.

③ F. LOCK Indicator

This indicator lights when the F. LOCK switch (18) is set to ON, indicating that the operating frequency is locked.

④ F. STEP Indicator

This indicator lights when the F. STEP switch is set to ON, indicating that the VFO step frequency is changed.

⑤ Meter

The meter has three functions. In receive the meter is automatically an S-meter showing receive strength on a scale of 1-9, 9+40 dB and 9+80 dB (the S meter deflects using the 50 MHz band as a reference, so it deflects much more than conventional meters in HF band). In transmit, the meter RF output or ALC level depending on meter switch (14) position.

⑥ VFO/MEMO (memory) Switch

VFO and MEMO (memory) channels can be selected by this switch.

⑦ MEMORY Selector

This switch is used to select memory channels (1-5CH). By using this switch, frequencies can be stored in or recalled from the selected channels.

In SCAN position, the transceiver is switched from VFO to memory SCAN; only the stored channel stops for a given time and then it shifts to the next channel. Stop and restart of SCAN is accomplished by the HOLD switch (9).

⑧ M Switch

This switch is used to store frequencies into memory channels. With the switch depressed, a beep is heard to indicate that the displayed frequency is stored in memory.

⑨ HOLD Switch

Used to stop or restart memory SCAN operation.

⑩ MODE Switch

Used to select operating modes, FM, SSB, CW and AM.

⑪ MIC (microphone) Connector

For connection of the supplied microphone.

⑫ PHONES Jack

For connection of a headphone with 8-16 ohm impedance. Specially designed communication headphones HS-5 and HS-4 are available as optional accessories.

A stereo headphone can also be directly connected.

⑬ Standby Switch

This switch selects receive or transmit function. In the REC (■) position, the transceiver is normally in receive mode unless the microphone PTT switch is depressed.

In the SEND (■) position, the TS-660 is switched to the transmit mode.

Caution:

Do not transmit when the antenna system is not perfect (ANT terminal is open or shorted), as it can result in damage to the equipment.

⑭ Meter Switch

During transmission, the meter switch determines meter function. The switch selects between:

- **RF:** In this position, the meter monitors the relative RF output of the transceiver.
- **ALC:** The meter monitors the output of the final stage power amplifier during transmission. During SSB operation, adjust the MIC control so that the meter is within the ALC zone. Similarly, adjust the CAR control for CW operation.

⑮ Tuning Control

This control is used to select the desired operating frequency. One rotation of the control covers the following frequencies:

F. STEP Switch

MODE \ Switch	OFF	ON
SSB, CW, AM	10 kHz	100 kHz
FM	500 kHz	100 kHz

⑯ RIT Switch

RIT (Receiver Incremental Tuning) ON/OFF switch. Depress the switch to turn ON. Depress it once again to turn OFF. The RIT indicator lights when the RIT circuit is ON.

⑰ NB (noise blanker) Switch

This switch is used to reduce pulsating ignition noises of the type usually emitted from motor vehicles.

⑱ F. LOCK Switch

This switch is used to lock VFO frequency in use. In the ON position, the frequency stays locked even when the BAND switch or tuning control is manipulated. This feature is useful for continued operation with the same frequency or mobile operation.

The RIT switch functions even in the ON position of the F. LOCK switch. The F. LOCK indicator lights when the switch is ON.

⑲ F. STEP Switch

This switch is used to select step frequency during VFO operation. Operating conditions are indicated by the light of the F. STEP indicator.

F. STEP Switch

MODE \ Switch	OFF	ON
SSB, CW, AM	10 Hz	100 Hz
FM	10 kHz	100 Hz

⑳ Function Switch

This switch selects the functions of transmit and receive operations. Normally, this switch should be set to "A" or "B".

- **A-R:** In this position, VFO-A functions for reception and VFO-B for transmission.
- **A:** VFO-A functions for transmission and reception.
- **B:** VFO-B functions for transmission and reception.
- **B-R:** VFO-B functions for reception and VFO-A for transmission.

㉑ SQL (squelch) Control

Used for squelch adjustment. A clockwise turn will operate the squelch. The control functions for all modes, FM, SSB, AM and CW.

㉒ CAR (carrier level) Control

Used for carrier level adjustment in CW or AM mode only.

㉓ MIC (MIC gain) Control

This control adjusts the microphone amplifier gain in SSB mode. Adjust so that the reading of the ALC meter does not exceed the ALC zone.

㉔ RIT Indicator

A light emitting diode indicator indicates RIT circuit ON or OFF. The indicator lights when the RIT switch is in ON position.

㉕ RIT Control

When the RIT circuit is ON, this will vary receive frequency by about ± 1 kHz. When the control is set to the "0" center position, there is no frequency shift (RIT OFF).

㉖ IF SHIFT Control

By using this control, the IF crystal filter center frequency can be shifted ± 1 kHz, allowing adjustment of tone quality, or eliminating interference from adjacent frequencies. For normal operation, this control should be set to the center "0" (click is heard) position.

27 AF (audio gain) Control

This control adjusts the receiver audio amplifier gain. Volume of the received signal increases as the control is turned clockwise.

28 RF (RF gain) Control

This adjusts the receiver section's RF amplifier gain. Turn the control fully clockwise for maximum gain. Turn counterclockwise to reduce the gain.

29 POWER Switch

Turns ON and OFF the TS-660.

30 BAND Switch

This switch selects all bands, 21, 24, 28-29 MHz and 50-53 MHz. In the UP position of the switch, the operating bands are shifted up one by one. In the DOWN position, the operating bands are shifted down (bands are shifted in 1 MHz steps).

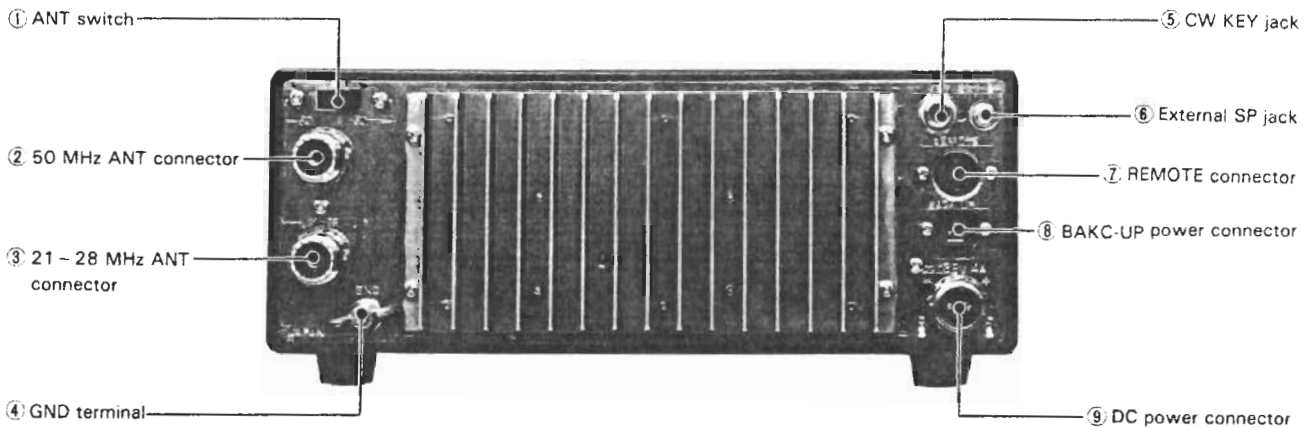

3.2 REAR PANEL

1 ANT (antenna) Switch

When using an antenna covering 21-50 MHz band, connect it to the 50 MHz antenna connector and set this switch to "21-50". When using 21-28 MHz and 50 MHz antennas, set the switch to the other position.

2 50 MHz Antenna Connector

For connection of 50 MHz or 21-50 MHz band antenna.

3 21-28 MHz Antenna Connector

For connection of 21-28 MHz band antenna.

4 GND Terminal

The TS-660 should be grounded through this terminal to avoid the possibility of TVI and BCI.

5 CW KEY Jack

For CW operation, connect your key to this terminal using a phone plug.

6 External SP Jack

An external speaker of 8-16 ohms impedance can be connected here. For connection use the supplied plug.

7 REMOTE Connector

Use this connector when the TS-660 is operated in conjunction with an external device. This connector is internally connected as shown in the illustration. For connection use the supplied 7P DIN plug.

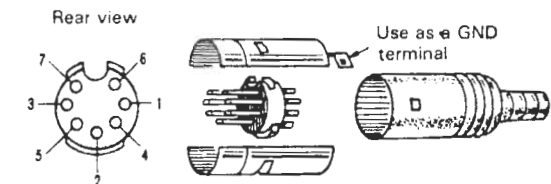
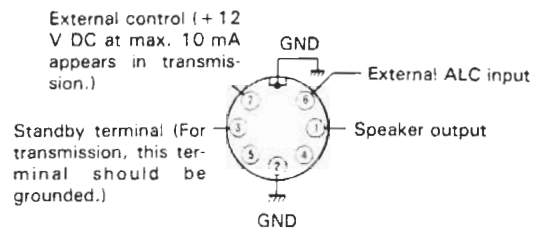

8 BACK-UP Power Connector

By using this connector, the built-in micro-computer is backed up (holds VFO frequency stored in memory) even when the power is OFF.

(For back-up power supply, use the optional accessory BC-1.)

⑨ **DC Power Connector**

This is used to connect the DC power supply. For connection, use the supplied power cord (with plug). The standard voltage is 13.8 V. When connecting, care should be taken with regard to the “+” and “-” polarity.

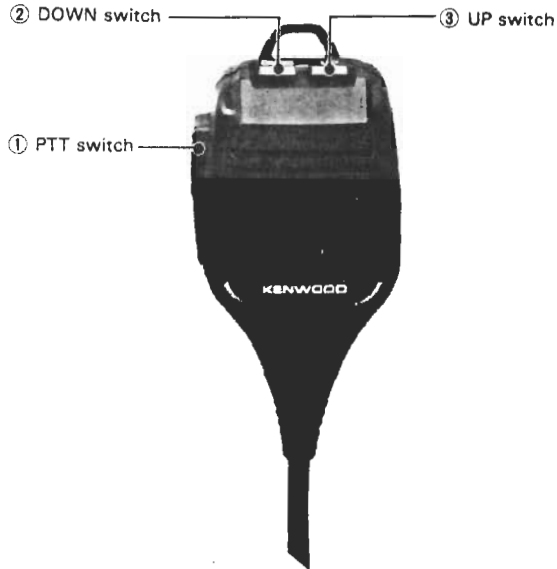

3.3 MICROPHONE

① **PTT Switch**

Press-to-talk switch used for transmission.

② **DOWN Switch**

This switch is used to shift DOWN the digital VFO frequency.

③ **UP Switch**

This switch is used to shift UP the digital VFO frequency.

SECTION 4. OPERATION

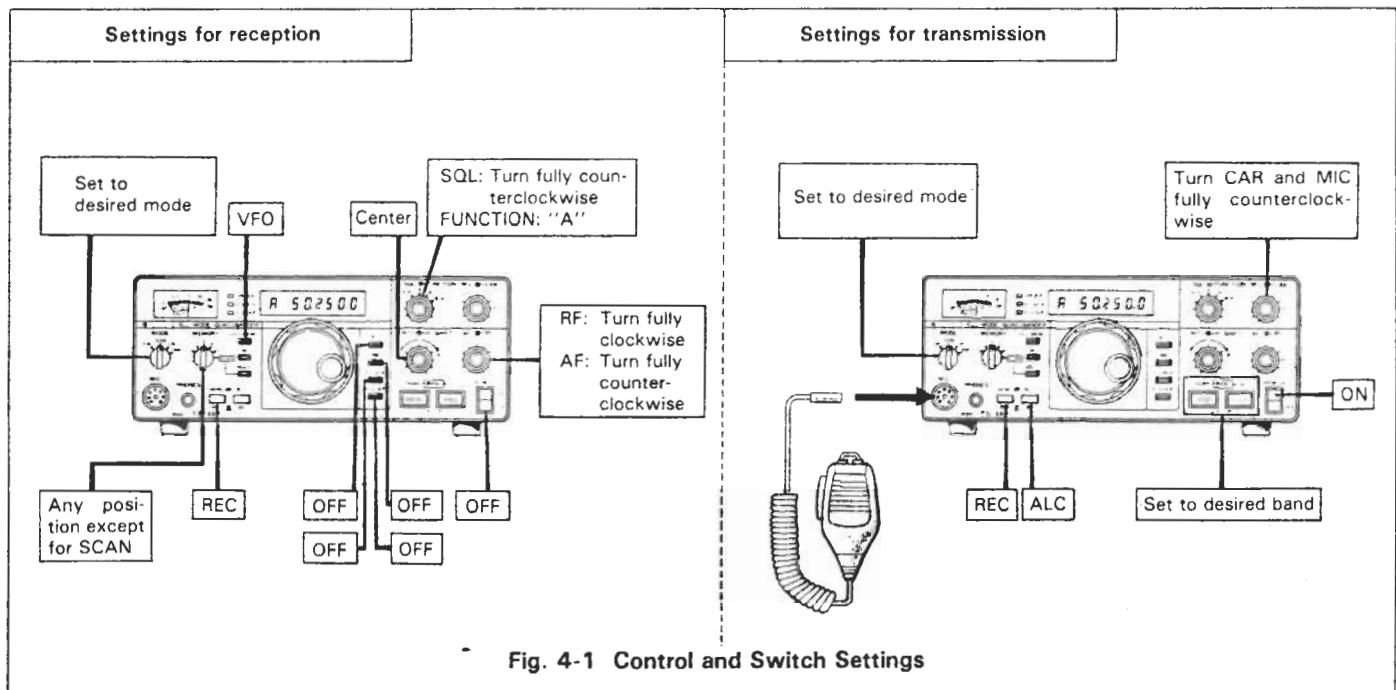

Fig. 4-1 Control and Switch Settings

4.1 RECEPTION

First connect the antenna, microphone and key. Then, set the controls and switches referring to Fig. 4-1.

In SSB, the USB band is normally used for reception of signals of more than 10 MHz. The SSB mode of the TS-660 is automatically set to USB.

Ascertain that the TS-660 is ready for operation, then turn the POWER switch ON. A beep is heard and the meter is illuminated. Also, the digital display indicates "R" and "50.000.0", indicating that the transceiver is in operation.

The transceiver is fully solid-state, allowing reception as soon as the POWER switch is turned ON.

Next, depress the BAND switch (30) to tune in the desired band. Turn the AF GAIN control clockwise until some receiver noise is heard from the speaker. Adjust the volume to a suitable level.

Turn the VFO tuning control slowly so the desired signal can be heard clearly.

Note:

A faint beat will be heard at 52.000 MHz. This is normal and is in no way an indication of trouble.

4.1.1 RIT Control

By using the RIT control (Receiver Incremental Tuning), the receive frequency can be shifted by about ± 1 kHz without changing the transmit frequency. If the frequency of the station you are working changes, your receive frequency can be reset by turning the RIT switch ON and adjusting the RIT control. Adjusting the control clockwise increases the frequency and vice versa. The RIT shift can be checked

by the digital display.

When first calling another station, the RIT should be OFF, otherwise your transmit and receive frequencies will not coincide.

4.1.2 NB Switch

The TS-660 has a sophisticated noise blanker designed to reduce ignition-type pulse noise. The noise blanker is particularly important for mobile operation. When necessary, activate the noise-blanker by depressing the NB switch ON.

4.1.3 SQL (Squelch) Control

To eliminate noise at no-signal condition, turn the SQL control clockwise until the noise disappears (normally threshold point).

By so doing, the sound from the speaker is heard only when the signal from your working station is received.

If the signal is weak or fades during mobile operation, readjust the squelch for the clearest reception.

(The squelch functions on all modes, FM, SSB, CW and AM; however, the squelch level is slightly varied depending on the mode of operation.)

Note that excessive turning the RF control counterclockwise disables the squelch function.

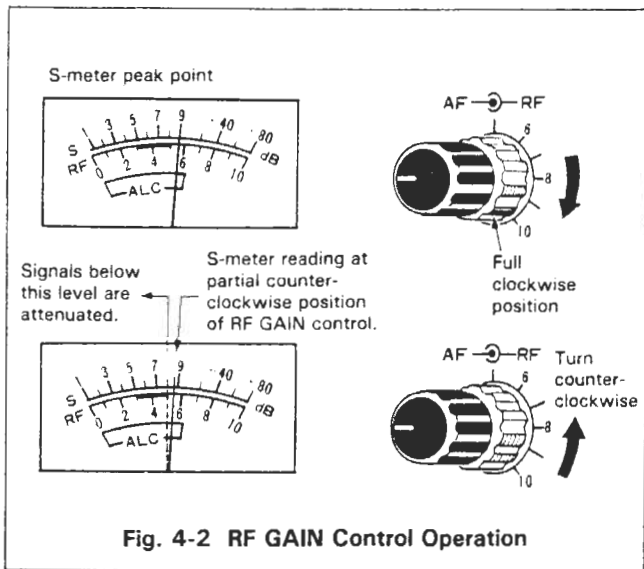

4.1.4 RF GAIN Control

For normal operation, this control should be turned fully clockwise for maximum sensitivity. Receive sensitivity is reduced by turning the control counterclockwise. Adjust the RF GAIN so the S-meter does not show excessive deflection. This minimizes noise during reception and allows the S-meter to indicate signal peak (or a little below that point). Noise is markedly reduced when signal is absent.

4.1.5 IF SHIFT Control

The IF SHIFT control is used to shift the passband of the IF filter without changing receive frequency. By turning this control in either direction, the IF passband is shifted as shown in Fig. 4-3.

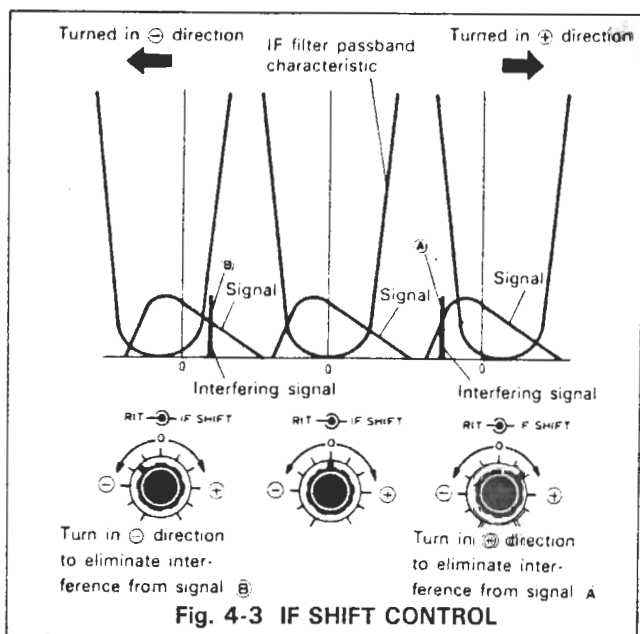

The IF SHIFT is effective in eliminating interference when the receive signal is superimposed on nearby signals during operation in both SSB or CW mode.

- **SSB mode**

Adjust the IF SHIFT control in the “+” direction and lower frequencies are cut.

Adjust the control in the “-” direction and high frequencies are cut.

- **CW mode**

By using the IF SHIFT in conjunction with the RIT, tone quality can be adjusted.

4.2 TRANSMISSION

Caution:

Before transmitting, be sure to connect an antenna or dummy load with a VSWR of less than 1.5. Never attempt to transmit with the antenna left open or short circuit.

When testing the transmitter, connect a 50-ohm dummy load, rated at more than 10 W, to prevent interference to other stations.

Dummy load RD-15 (15 W) is available as an optional accessory.

- **SSB operation**

- 1) Set the MODE switch to SSB.
- 2) Meter switch to ALC.
- 3) Standby switch to SEND.
- 4) Speak into the microphone and adjust the MIC GAIN for meter deflection within the ALC zone at signal peaks.

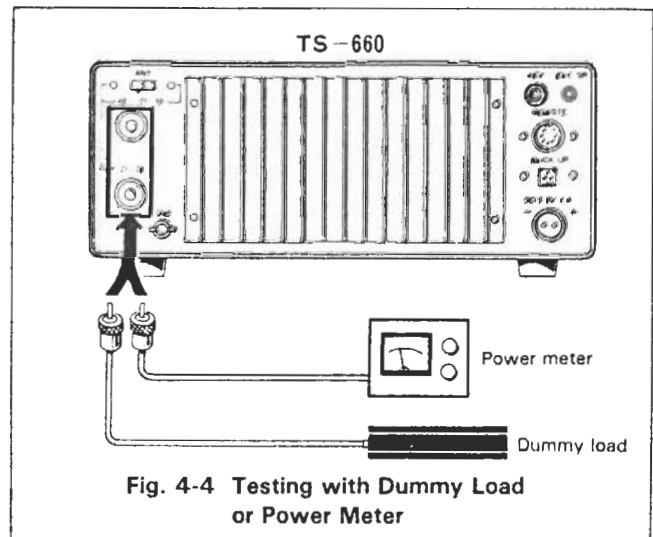

- **CW operation**

- 1) Set the MODE switch to CW and the meter switch to ALC.
- 2) Set the standby switch to SEND and adjust the CAR control so the meter deflects within the ALC zone. If a key is connected, it should be depressed during the adjustment.

Notes:

1. In CW mode, no signals are transmitted for about 10 seconds after the POWER switch is turned ON.
2. When a key is connected to the KEY jack, the transceiver is in semi-break-in operation if the standby switch is set to REC.

• **AM operation**

- 1) Set the MODE switch to AM and the meter switch to RF.
- 2) Set the standby switch to SEND and adjust the CAR control so the meter deflects a little over 1/2 of the deflection at full clockwise position of the control (use the meter reading as an approximate guide).
- 3) Set the meter switch to ALC. Speak into the microphone and adjust the MIC GAIN control so the meter pointer swings slightly at peaks of voice. Note that excessive meter deflection can result in over-modulation or modulation noise.

• **FM operation**

- 1) Set the MODE switch to FM and the meter switch to RF.
 - 2) Set the standby switch to SEND.
 - 3) Speak into the microphone.
- In FM mode, the MIC GAIN, CAR controls and the meter switch are not used.

4.2.1 Final Stage Protection

The TS-660 features a VSWR protection circuit to protect the final-amplifier transistors. Without this circuit, the load of the final stage transistors will be increased, if the antenna system impedance is incorrect and the VSWR is high.

4.2.2 MIC GAIN Control

This control adjusts the microphone input level. When using the TS-660 in SSB mode, connect a microphone and set the standby switch to SEND (antenna or dummy load must be connected). Set the meter switch to ALC and speak into the microphone.

Adjust the MIC GAIN control so the meter does not deflect out of the ALC zone at peak signals (see Fig. 4-5).

• **ALC (Automatic Level Control)**

The ALC monitors the transmitter final stage output to minimize distortion in your transmit signal. It automatically adjusts output to an optimum level.

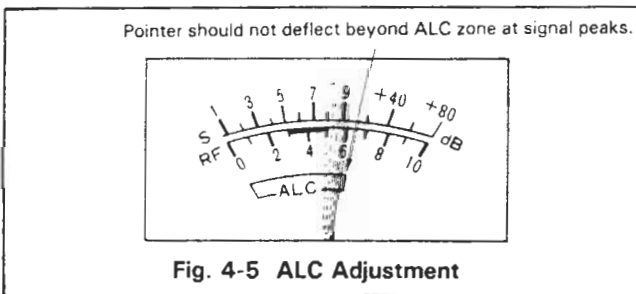

4.3 BAND (UP-DOWN) SWITCH

The feather touch BAND switch functions respectively for VFOs: A and B (see 4.4 "2 VFO operation"). A beep sound will be heard to prevent misoperation when the switch is manipulated. The BAND switch operates at 21, 24, 28, 29, 50 ... 53 successively. Set your desired band by the UP or DOWN switch. The frequency is shifted UP or DOWN continuously when the switch is kept depressed. This switch is not effective in transmission.

4.4 2-VFO OPERATION

The TS-660 VFO has 2 positions, A and B., each being controlled by the built-in micro-computer. By using the FUNCTION switch, VFO: A and VFO: B plus VFO: A-R and VFO: B-R used for cross channel operation can be selected. This feature enables you to operate two receivers and two transmitters with the TS-660 alone. The relation between the positions of the FUNCTION and the operation is shown in Table below.

FUNCTION switch	Receive	Transmit
A-R	A	B
A	A	A
B	B	B
B-R	B	A

With the VFO: A and B, operation on different bands (for example, VFO: A 50 MHz, VFO: B 21 MHz) or the same band is also possible. Furthermore, the VFO: A and B can be used as a memory.

(Example 1)

The VFO: B is used as a memory to store the schedule frequency of the working station and the VFO: A is used for operation until the signal of the working station is received.

(Example 2)

Unused VFO can be used to search a sub-channel when it is designated in FM mode.

Use the VFO: A and B as stated above for more enjoyable operation.

4.5 F. STEP SWITCH

This switch is used to select the frequency step of the VFO in each mode.

F. STEP switch \ Mode	SSB, CW, AM	FM
OFF	10 Hz	10 kHz
ON	100 Hz	100 Hz

In the SSB, CW and AM modes, the F. STEP switch should be set to OFF. To advance the tuning control quickly, set the switch to ON. While advancing the frequency quickly, adjust the control to the approximate frequency, then set the switch to OFF for fine adjustment. The F. STEP switch may be set to OFF for effective operation in FM mode.

4.6 MEMORY

The M switch is used to store a frequently used frequency in memory.

The frequency selected by the tuning control can be stored in any memory channel (1 through 5 channel) of the MEMORY SELECTOR by using the M switch. The stored frequency can be called back by setting the VFO/MEMO switch (6) to MEMO.

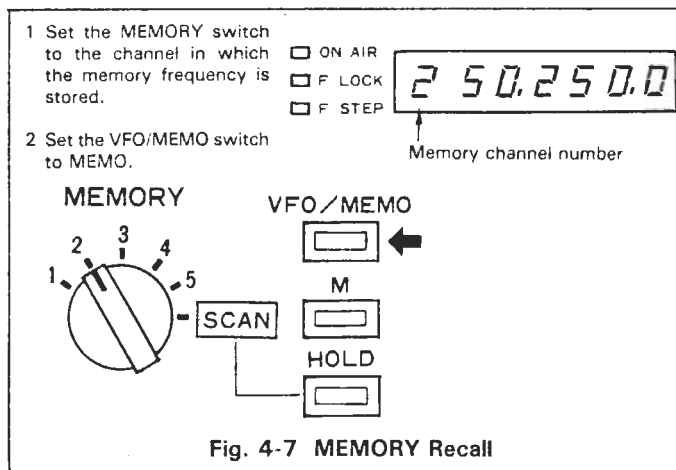
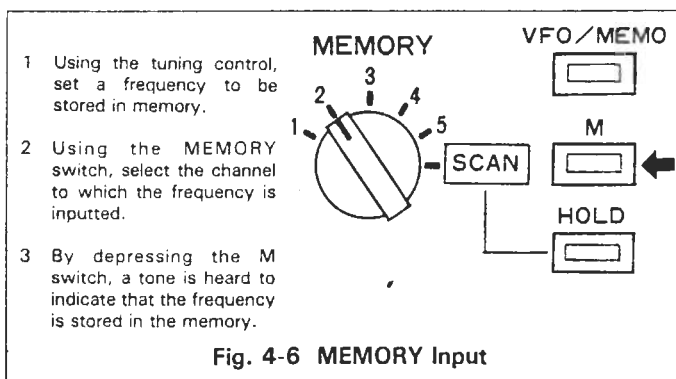

In the SCAN position of the MEMORY selector knob, the frequency is switched from VFO to SCAN; only the channel frequency stored in memory stops for a given time (approx. 2.5 sec) and then it is shifted to the next channel. The HOLD switch is used to stop and restart the scan. The memory SCAN is independent of the position of the VFO/MEMO switch.

Notes:

1. SCAN operation stops during transmission and begins again in case the transceiver returns to reception.

Transmit always after stopping scan operation by the HOLD switch.

2. When the VFO/MEMO switch is depressed and then released, the VFO frequency is shifted by a maximum of 90 Hz.

4.7 CW OPERATION

For CW operation, your transmit frequency should be "zeroed" to the transmit frequency of your contact station. Receive frequency is 800 Hz lower than the transmit frequency of your contact station, so that his signal is received as an 800 Hz beat note. This also allows your contact station to receive your signal without having to return his receiver. In CW mode, the receive VFO point is indicated on the digital display.

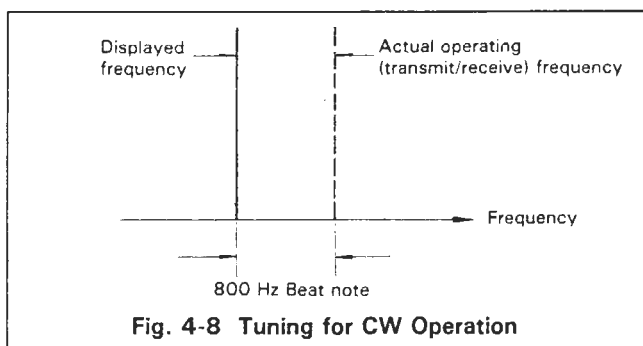

When the standby switch is in the REC position, the TS-660 is set in semi-break-in operation. In the SEND position of the switch, the transmitter operates in normal CW mode.

The semi-break-in operation utilizes a side tone to operate the transmitter when the key is depressed and to operate the receiver when the key is released.

The TS-660 incorporates its own built-in side tone oscillator circuit so the keying signals can be monitored by an audio frequency sound of about 800 Hz.

The DELAY TIME and SIDE TONE LEVEL can be adjusted as desired. For adjustment, open the case (See Fig. 4-9).

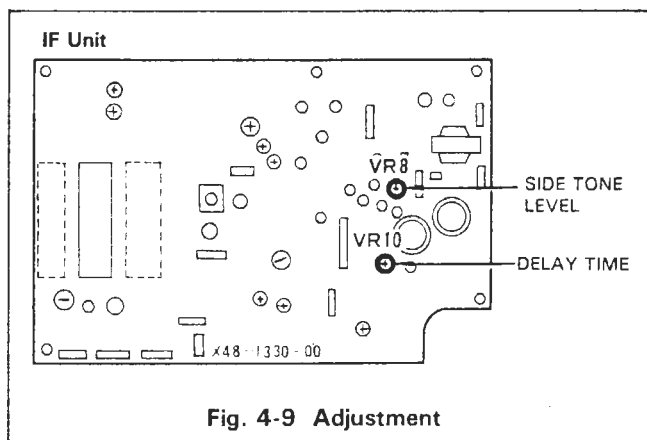

Tuning methods (zero-in) are detailed in the following paragraphs.

4.7.1 Operation without CW filter (beat tone method)

Set the IF SHIFT control to its center position and the RIT switch OFF. Adjust the main tuning control for an 800 Hz beat note and your transmit frequency will then coincide with that of your contact station ("zeroed").

The 800 Hz beat note is similar to the 800 Hz side tone (monitor tone in key operation).

You may now adjust the RIT for a pitch which suits your preference with the RIT switch set to ON. If interference is encountered, adjust the IF SHIFT. For more convenient and effective CW operation, use of the optional YK-88C or YK-88CN CW crystal filter is recommended.

4.7.2 Operation with CW filter (YK-88C or YK-88CN)

Set the IF SHIFT to its center position and the RIT to OFF. Adjust the main tuning control for maximum deflection of the S-meter. Receive signal pitch will be about 800 Hz, indicating correct tuning.

4.7.3 Key connection

Your key should be connected as illustrated in Fig. 4-10, making sure that the polarity is correct.

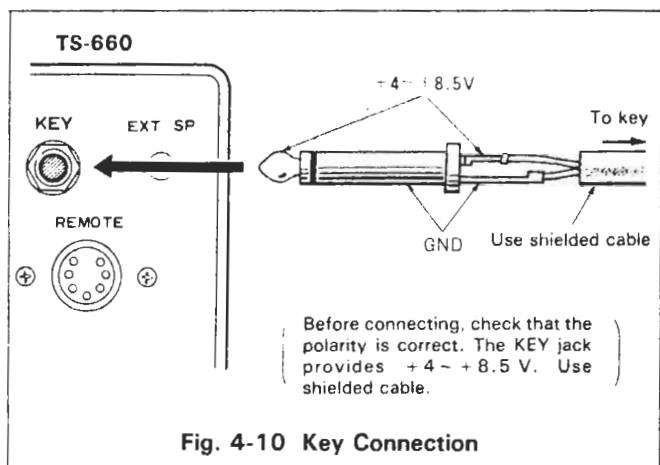

Fig. 4-10 Key Connection

4.8 MOBILE OPERATION

The TS-660 being compact in design, is ideal for mobile operation. Satisfactory mobile operation is achieved through proper power and antenna connection, and thoughtful transceiver installation and adjustment.

4.8.1 TS-660 installation

Secure the TS-660 under the dashboard using an optional MB-100 mounting bracket as shown in Fig. 4-11. As an alternative, use strapping, making sure that the TS-660 will not slip out of place while driving the vehicle.

Notes:

1. Do not install the TS-660 near the heater outlet.
2. Allow sufficient space behind the TS-660 to ensure proper ventilation.

4.8.2 How to handle the power cable

When connecting or disconnecting the power cable to or from the power connector, be sure that the power switch is always OFF. Observe the polarity of the cable (red: "+", red/black: "-").

Connect the TS-660 power cable to the battery terminals, with consideration to current requirements and noise prevention. When connecting, care should be taken so that no adverse effects occur in the vehicle's power supply system (battery, etc.). Extend the power cable from the engine room of the vehicle as shown in Fig. 4-11, using wiring packings. Keep the power cable away from the high voltage wiring connected to the engine's ignition plug.

4.8.3 Mobile antenna

The HF/VHF mobile antenna should be secured to the body of the vehicle using an antenna bracket (preferably, bumper mount type) available from market.

(1) Antenna installation

Use a rugged mount for the mobile antenna because HF antennas are larger (and have more wind load) and are heavier than VHF antennas. A bumper mount shown in Fig. 4-11 is recommended for general use. The ground side of the mount must be grounded to the body of the car since the body itself functions as the ground plane for the mobile antenna (see Fig. 4-11).

Notes:

1. Some cars have a urethane plastic bumper. For such cars, ground the antenna mount to the body.
2. When tuning the newly installed antenna whose impedance is unknown, use the following procedure:
 - Turn the CAR control fully counter-clockwise for minimum transmit output.
 - With the transceiver in transmit mode, raise transmit power output slowly by rotating the CAR control clockwise. The VSWR of normal antenna systems can be measured without raising the power output to maximum.
 - Transmitting with full power is recommended after the antenna is adjusted (VSWR: less than 1.5).

(2) Coaxial cable connection (see Fig. 4-11)

When the antenna is mounted on the vehicle's bumper, the coaxial cable from the antenna can be routed through a drain hole in the trunk. The cable can be extended from the trunk to the driver's room by opening the back seat. When the antenna is roof mounted, pass the cable through the bottom of the door step; for a 2-door type vehicle, pass the cable through the rear window.

In this case, care should be taken so that rain water will not enter the vehicle through the cable.

4.8.4 Noise Reduction in Mobile operation

In motor vehicles, ignition noise is generated by the ignition coil or distributor. Other sources of noise include the wiper and heater motor.

Although the TS-660 is equipped with a noise blanker to minimize ignition noise, it is imperative that some preventive measures be taken to reduce the noise to the lowest possible level.

(1) Antenna location selection

Since ignition noise is generated by the vehicle's engine, the antenna must be installed as far from the engine as possible.

(2) Use ignition suppressor spark plug

Noise can be reduced by using spark plugs with internal

resistors, or resistive suppressor cable available from market. Contact your vehicle maker, dealer or car service shop.

(3) Bonding

The component parts of motor vehicle, such as the engine, transmission, muffler system, accelerator, etc., are coupled together at DC and low frequencies, but are isolated at high frequencies. By connecting these parts using heavy, braided ground straps, ignition noise can be reduced. This connection is called "bonding".

(4) Battery power connection

It is recommended that battery power be supplied directly to the TS-660 from the battery terminals. Connect the negative side of the battery to a point, close to the transceiver, where the noise can be minimized.

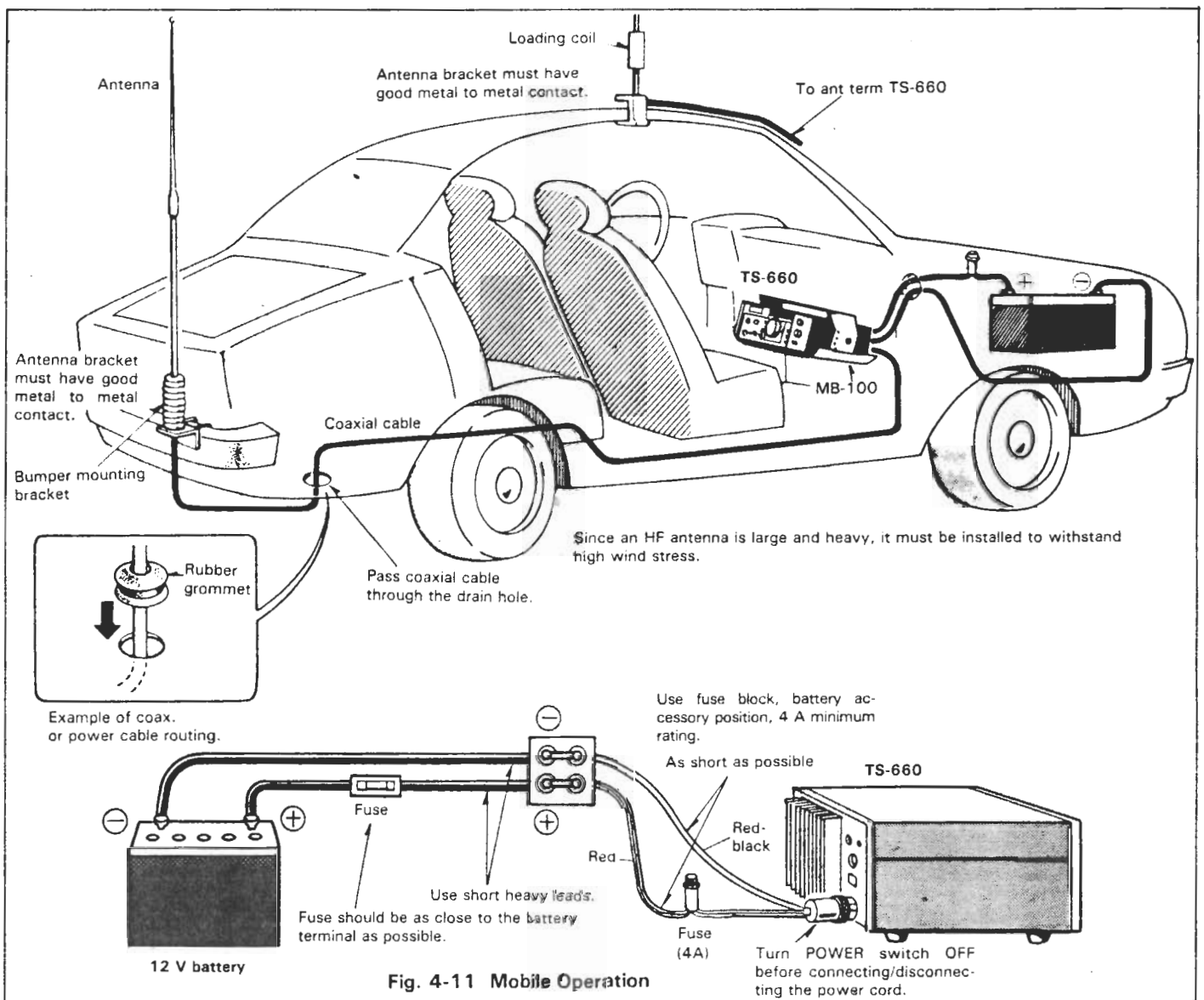
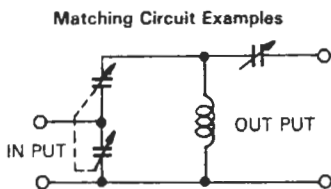

Fig. 4-11 Mobile Operation

4.8.5 Antenna Matching

Mobile antennas use a 1/4 wave length and, in 21 MHz band, the antenna length is as large as about 3.5 m, so the length is reduced by using a tight wound coil or by winding the element in a helical shape. In general mobile antennas have a low impedance. When it is connected to the TS-660 with a 50 ohm coaxial cable, the SWR becomes high, affecting the performance of the transceiver. Such trouble can be eliminated by using an antenna tuner between the TS-660 and the coaxial cable, particularly when the SWR is higher than "2".

Since mobile antennas are generally narrow in bandwidth, adjust the antenna for a minimum SWR at very frequently used frequency.



4.8.6 Battery Capacity

The power system of a motor vehicle is comprised of a battery and an alternator (which generates power while the engine is running) to supply current to loads or to charge the battery.

Since the transceiver draws high current during transmit, care should be exercised so that the power system is not overloaded. When using the transceiver, the following points should be observed from the viewpoint of battery maintenance.

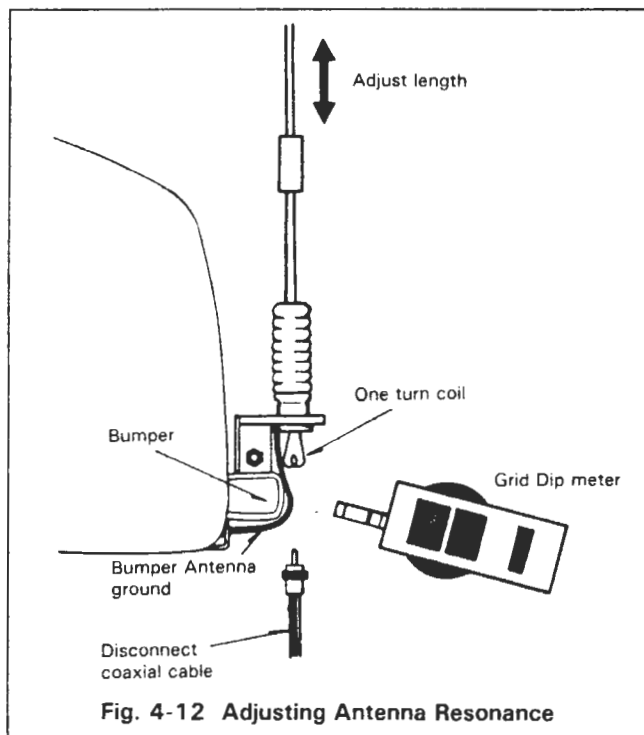

Fig. 4-12 Adjusting Antenna Resonance

1. Turn the transceiver OFF when the lights, heater, wipers and other high-draw accessories are used.
2. Avoid transceiver operation when the engine is not running.
3. If necessary, use an ammeter and/or a voltmeter to check battery condition.

4.9 FIXED STATION OPERATION

4.9.1 Power Connection

The TS-660 power requirement is 4A at 13.8 V DC when transmitting with full power. The optional power supply Model PS-20 is available for fixed station operation, which matches the TS-660 in design and performance.

4.9.2 Antenna

For HF/VHF fixed station operation, an antenna specifically designed for amateur operation is recommended.

Antenna types include the wire antennas, verticals, rotary beam, and other antennas. HF antennas are quite large and must be installed to withstand strong wind, heavy rain, etc. Any antenna used with the TS-660 should be of 50 ohm impedance and should be connected using an appropriate coaxial cable such as RG-8/U.

Impedance matching is important. Impedance mismatching will result in a high VSWR and power loss, or can cause unwanted harmonic radiation and interference (TVI, BCI). The impedance match can be checked with an SWR meter. Generally, satisfactory operation is assured when the VSWR is less than 1.5; the optimum value of SWR is "1".

Note: SWR is also called VSWR, abbreviation for Voltage Standing Wave Ratio.

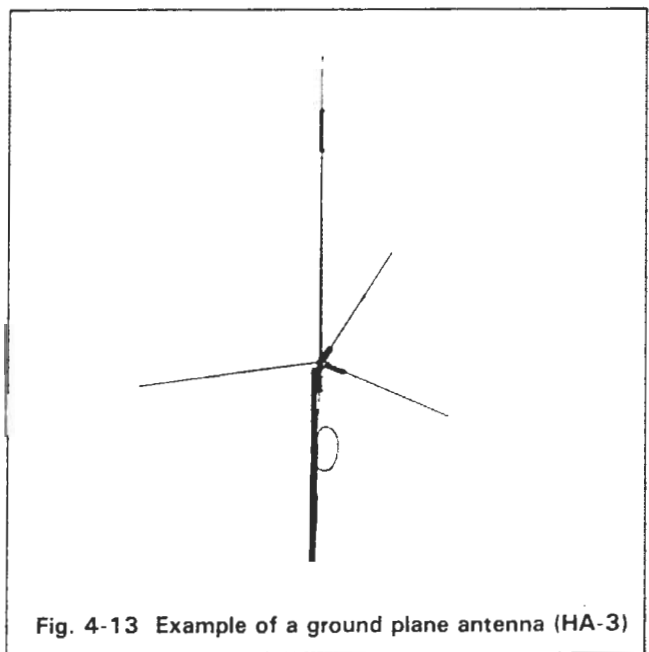

Fig. 4-13 Example of a ground plane antenna (HA-3)

SECTION 5. OPTIONAL ACCESSORIES

5.1 OPTIONAL ACCESSORIES

The following optional accessories are available for use with the TS-660.

■ Model PS-20 Regulated DC Power Supply

Perfectly matches the design and characteristics of the TS-660. Equipped with a protection circuit which guards transceiver against damage due to shorts or overload.

■ Model SP-120 External Speaker

The SP-120 is an external speaker designed exclusively for use with the TS-660. It matches the TS-660 in design and tone quality.

■ Model VOX-4 Voice Controller

In TS-660, selection between transmit and receive is accomplished by the standby switch or microphone PTT switch. The VOX-4 enables this selection by simply speaking into the microphone, without using the standby switch and PTT switch. Use of the VOX-4 will bring you more enjoyable operation.

■ Model TL-120 HF band Liner Amplifier

The TL-120 HF band compact liner amplifier can be used with the TS-660 at the input rating of 160 W in 21 MHz band and of 100 W in 28 MHz band.

■ Model HS-5 De-Luxe Headphones

Open-back type headphones designed for excellent tone quality and comfortable fit. The vented ear pads can be readily replaced with sealed cushions.

■ Model HS-4 Headphones

High performance dynamic microphone with specially designed ear pads for comfortable listening. Impedance: 8 ohms.

■ Model HC-10 Ham-Clock

A digital world-clock with dual display which can memorize up to 10 major cities and 2 additional regions.

■ Model BC-1 Battery Charger

A memory back-up power supply for fixed station operation. With the BC-1 connected, the memory is retained even when the main power supply is OFF.

■ Model YK-88C, YK-88CN CW Crystal Filter

Extremely sharp selectivity best suited for severe QRM in CW operation, and easy installation in TS-660.

YK-88C: 500 Hz (-6 dB), 1.5 kHz (-60 dB)

YK-88CN: 270 Hz (-6 dB), 1.1 kHz (-60 dB)

PS-20



SP-120



TL-120



HC-10

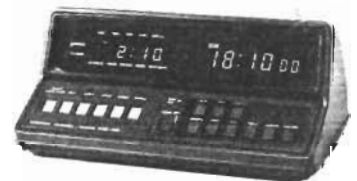

VOX-4



HS-5



HS-4



BC-1



■ **Model YK-88A AM Crystal Filter**

Selectivity is 6 kHz at -6 dB and 11 kHz at -60 dB. Designed for easy installation in TS-660.

■ **Model HA-3 3-Band Vertical Antenna**

A 3-band antenna (21, 28, 50 MHz) with high reliability and performance. Specifically designed for use in severe operating conditions.

■ **Model MB-100 Mobile Mount**

Designed mobile mount for mobile operation of TS-660. It can easily be attached and detached to and from the transceiver.

The MB-100 can either be suspended from the dashboard or rested on the floor of car. The mounting angle can be changed in 5 steps. Equipped with a burglar-proof key lock.

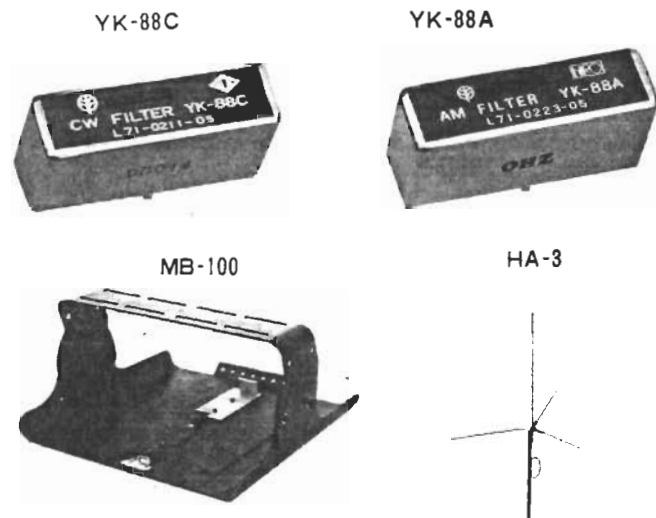

- 4) For soldering, use a small soldering iron. Soldering should be made as quickly as possible. Care should be used not to damage the leads when removing the IF unit.
- 5) When remounting the case, check to make sure that the speaker cord and connectors are firmly fit.

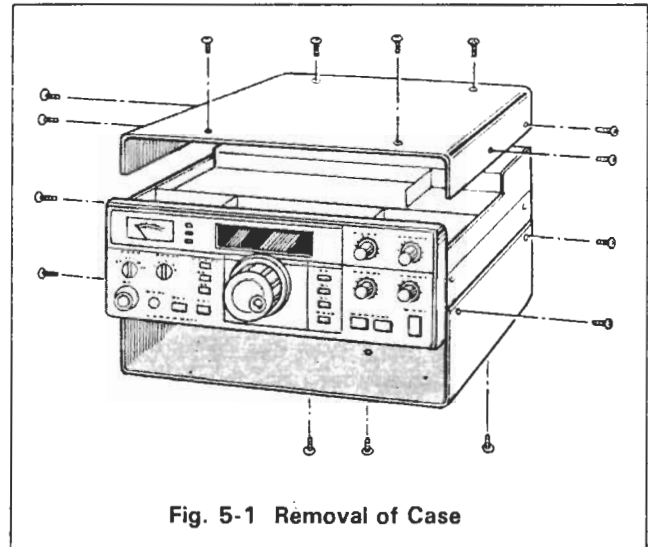

Fig. 5-1 Removal of Case

5.2.2 Installing the CW Crystal Filter (YK-88C/CN)

- 1) Remove the upper cover and bottom plate of the case.
- 2) Solder the filter positively in the open space for the filter on the IF unit circuit board (X48-1330-00) located on the upper left in the case.
- 3) Remove the pin connector connecting the jumper wire at the "S" terminal on the IF unit, then connect the wire to the "C" terminal.
- 4) Connect the speaker cord to the connector and remount the upper cover.

5.2 INSTALLING THE OPTIONAL PARTS

5.2.1 Before Installation

- 1) For installation, use the following tools:
 - Philips type screwdriver
 - Lead cutter or pliers
 - Nippers
 - Soldering iron (40 W)
 - Solder with flux
- 2) Before starting the work, be sure to disconnect the power cable.
- 3) Open the case by removing the screws holding the upper cover and the bottom plate of the case. A speaker is fitted to the upper cover, so care should be taken not to damage the speaker leads. Pull off the 2P connector connecting the speaker leads.

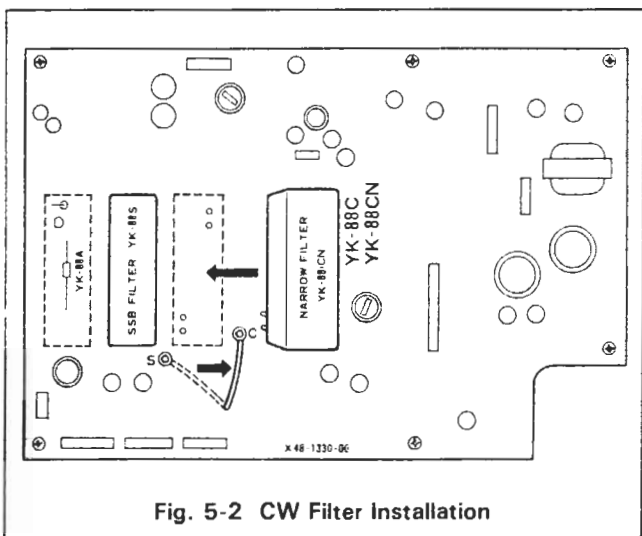

Fig. 5-2 CW Filter Installation

5.2.3 Installing the AM Crystal Filter (YK-88A)

- 1) Remove the upper cover and bottom plate of the case.
 - 2) Remove 2 screws holding the IF unit to the chassis at the IF unit circuit board (X48-1330-00).
 - 3) Raise the chassis holding the IF unit and cut off the leads of the resistor (4.7 k Ω) located in the center of the control unit (X53-1220-00).
 - 4) Remount the chassis.
 - 5) Remove the transistor (Q57) and resistors (R24, R91) located in the open space for optional filter on the IF unit circuit board (X48-1330-00) at the upper left in the case. Mount and solder the AM filter in the open space.
 - 6) Pull off the pin connector connecting the jumper wire to the "S-ONLY" terminal on the IF unit, then connect the wire to the "A" terminal.
 - 7) Connect the speaker cord to the connector and remount the bottom plate and upper cover.
- The above will complete the installation of the filter.

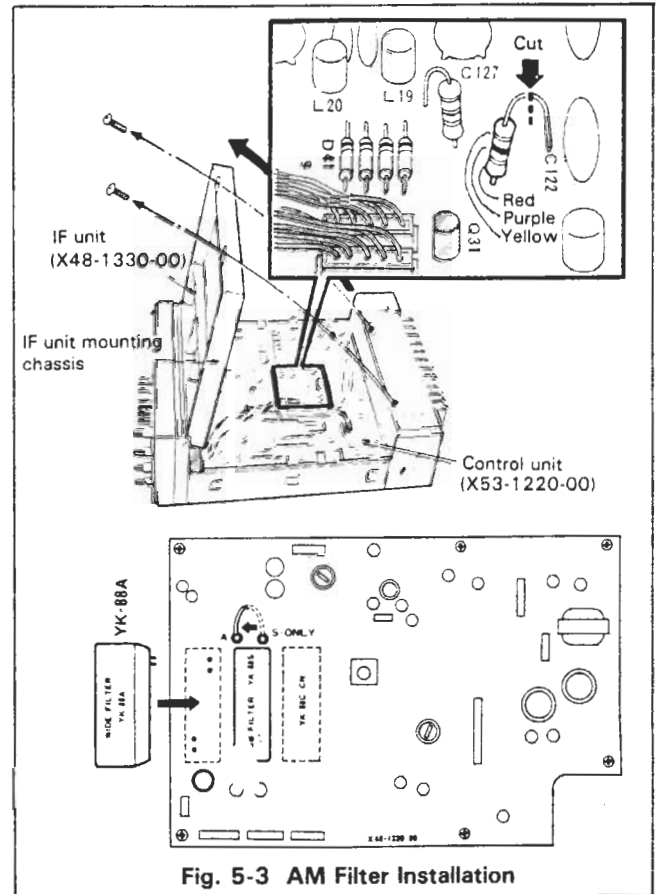

Fig. 5-3 AM Filter Installation

SECTION 6. ADDITIONAL INFORMATION

6.1 GENERAL INFORMATION

Your TS-660 has been factory aligned and tested to specification before shipment. Under normal circumstances, the transceiver will operate in accordance with these operating instructions.

If your transceiver fails to work, contact the authorized dealer from whom you purchased it for quick, reliable repair.

All adjustable trimmers and coils in your transceiver were preset at the factory and should only be readjusted by a qualified technician with proper test equipment.

Attempting service or alignment without factory authorization can void the transceiver's warranty.

6.2 HOW THE TX FINAL TRANSISTORS ARE PROTECTED

Final transistor protection is provided by sampling the reflected power. As the reflected power is increased (higher SWR) transmitter drive is reduced, thus decreasing

input to the final transistors. This in turn reduces collector loss, protecting the final transistors.

6.3 TRANSMITTING ON WARC BAND

If transmit capability is desired, just pull off the white lead located on the RF unit (X44-1440-00).

Refer to the bottom view on page 21.

SECTION 7. TROUBLESHOOTING

The problems described in this table are failures caused in general by improper operation or connection of the transceiver, not by defective components.

Transmitter Section

Symptoms	Cause	Remedy
No SSB output (RF and ALC meters are dead).	1. Loose connection of microphone jack. 2. MIC control is in minimum position.	1. Connect microphone firmly. 2. Turn MIC control clockwise.
No CW output.	1. Loose connection of KEY jack or poor contact of KEY. 2. CAR control in minimum position.	1. Connect the jack firmly. Repair the KEY contact. 2. Turn CAR control clockwise.
Over-modulation in AM, causing distortion.	Improper adjustments of CAR or MIC controls.	Readjust CAR or MIC controls.

Receiver Section

Symptoms	Cause	Remedy
Lamp remains OFF and speaker is dead when power switch is turned ON.	1. Poor connection of power cord to connector. 2. Blower fuse.	1. Connect power cord firmly. 2. Replace fuse (if new fuse blows, the transceiver is defective).
Frequency is not displayed (only "1" is displayed) when power switch is turned ON.	No frequency is inputted in memory channels. VFO/MEMO switch is in MEMO position.	Set VFO/MEMO switch to VFO. Input memory frequency.
No frequency is displayed or incorrect figures are displayed when power switch is turned ON.	Misoperation of micro-computer due to worn battery or excessive voltage drop.	1. Adjust power voltage to your line voltage using step-up transformer. Battery voltage should be 11-16 V. 2. Turn power switch ON once again.
No signal is received with antenna connected.	1. Squelch is operated. 2. MIC PTT switch is in SEND position or transceiver is in transmit mode.	1. Turn squelch control counterclockwise. 2. Set PTT switch to "receive" position.
Weak signal with antenna connected.	1. Wrong antenna connection (HF/VHF). 2. Antenna switch is in wrong position.	1. Check antenna and connect correctly. 2. Set antenna switch to the correct position.
No signal is received and S-meter scales out when antenna is connected.	RF control is set to low gain position.	Turn RF control fully clockwise.
S-meter deflects at no-signal time.	1. Power voltage is low. 2. RF control is set to low gain position.	1. Adjust power voltage to your line voltage using step-up transformer (PS-20). Battery voltage should be 11-16 V. 2. Turn RF control fully clockwise.
No sound is heard from speaker when signal is received.	MODE switch is in wrong position.	Set MODE switch to FM, SSB or AM.
Frequency remains the same when BAND SW is depressed or tuning control is turned.	1. F. LOCK SW is ON. 2. VFO/MEMO switch is in MEMO. 3. MEMORY selector is in SCAN.	1. Set F. LOCK SW to OFF. 2. Set VFO/MEMO switch to OFF. 3. Set to a position other than SCAN.
No SCAN operation.	1. HOLD SW is ON. 2. No input to MEMORY.	1. Set HOLD SW to OFF. 2. Apply input to MEMORY.
Display disappears at MEMORY.	When MEMORY CH is empty, "1" is displayed and no frequency is displayed.	Input memory frequency by MEMORY SW.

INTERNAL VIEWS

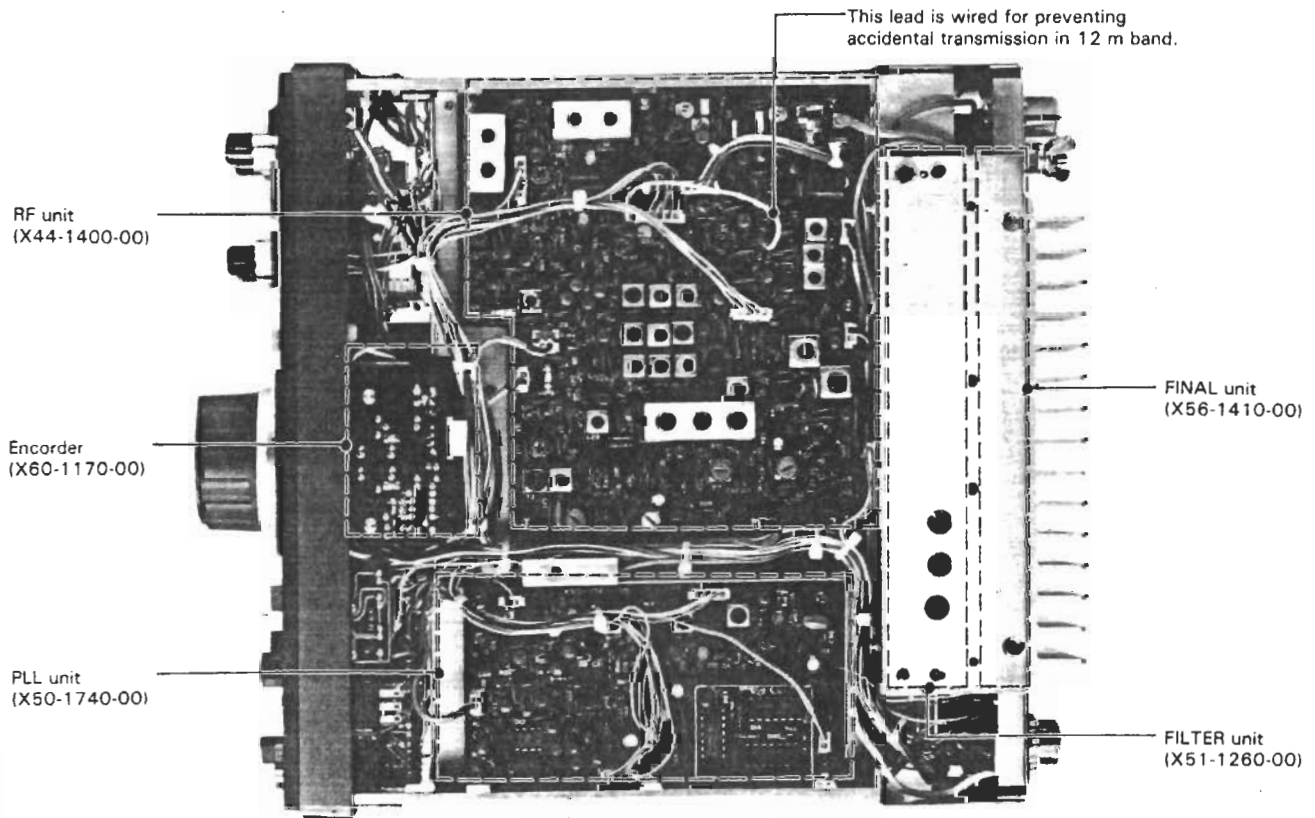
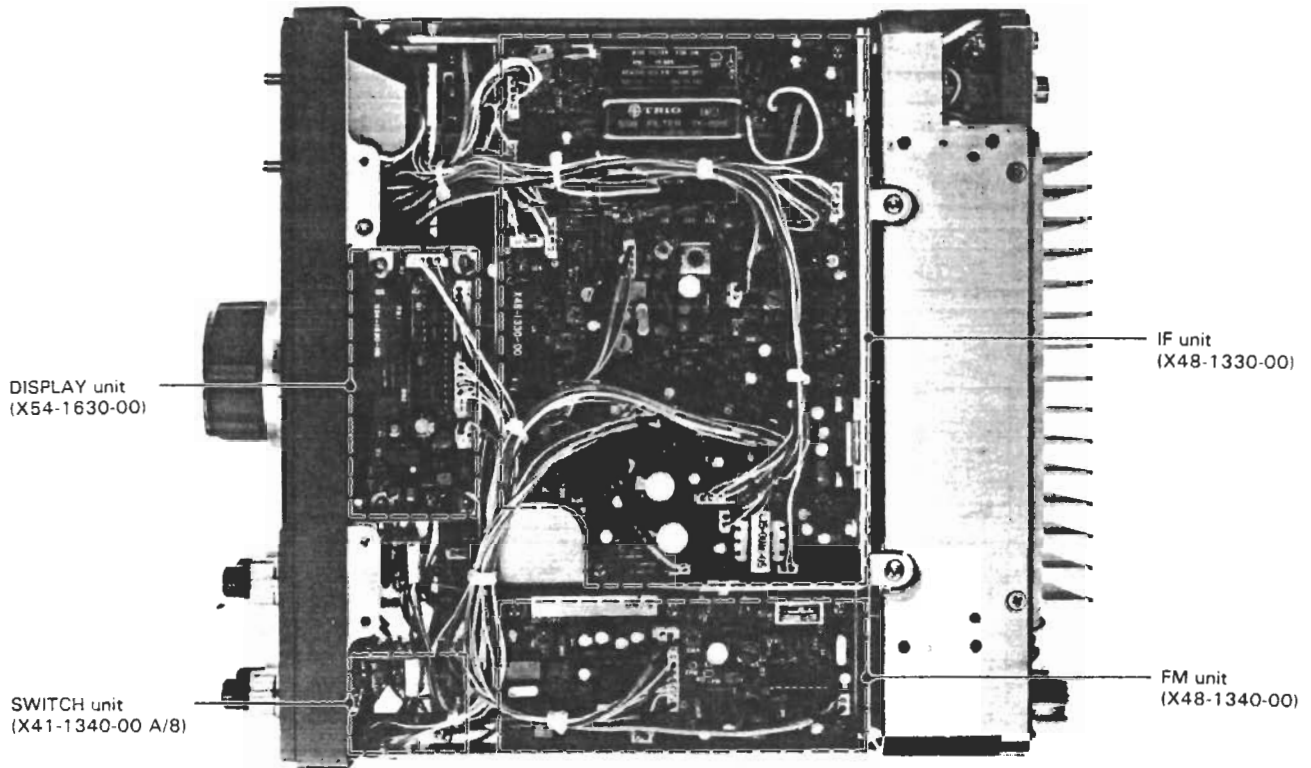

BLOCK DIAGRAM

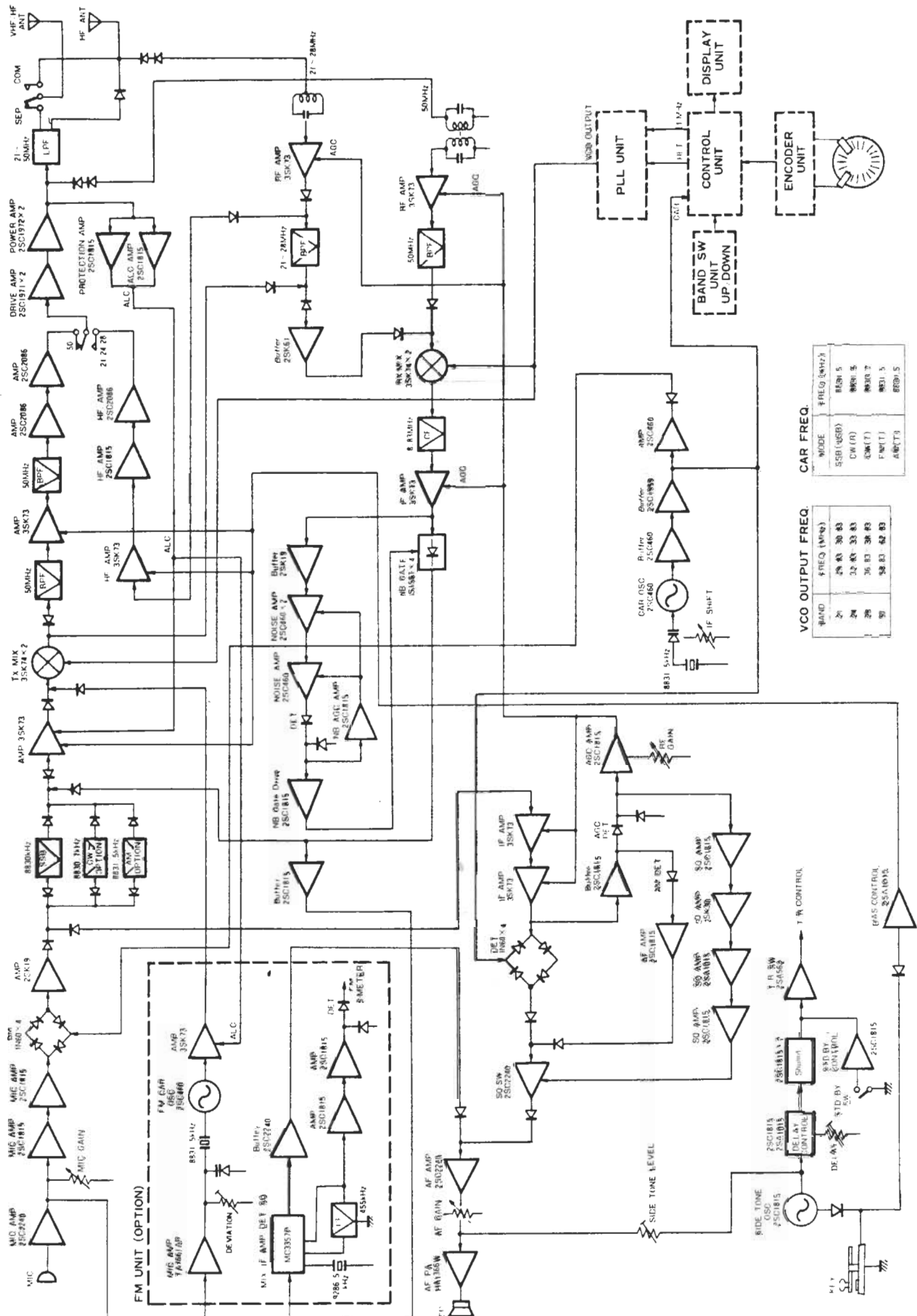

SCHEMATIC DIAGRAM

CONTROL UNIT (X53-1220-00)

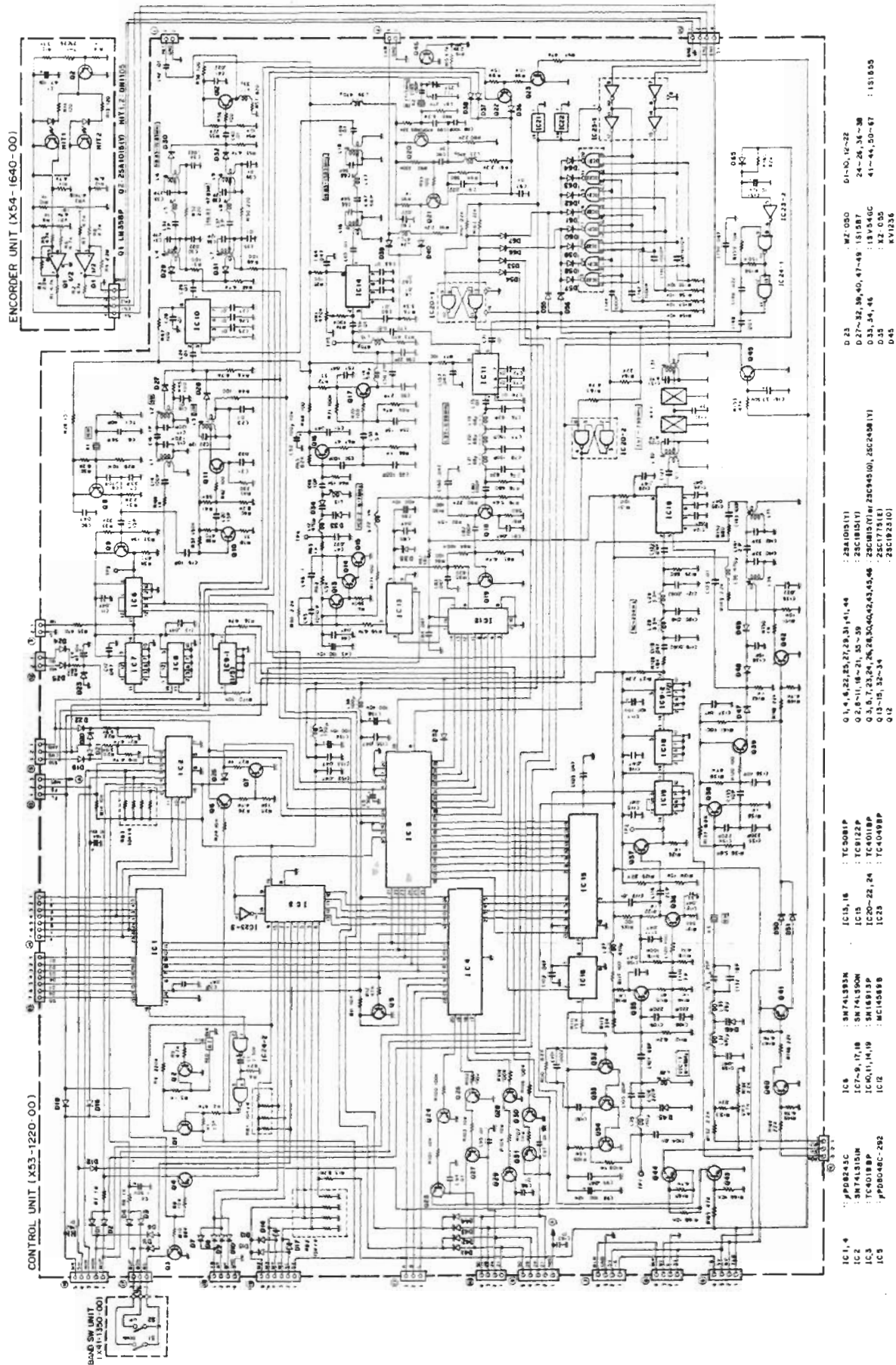

IF UNIT (X48-1330-00)

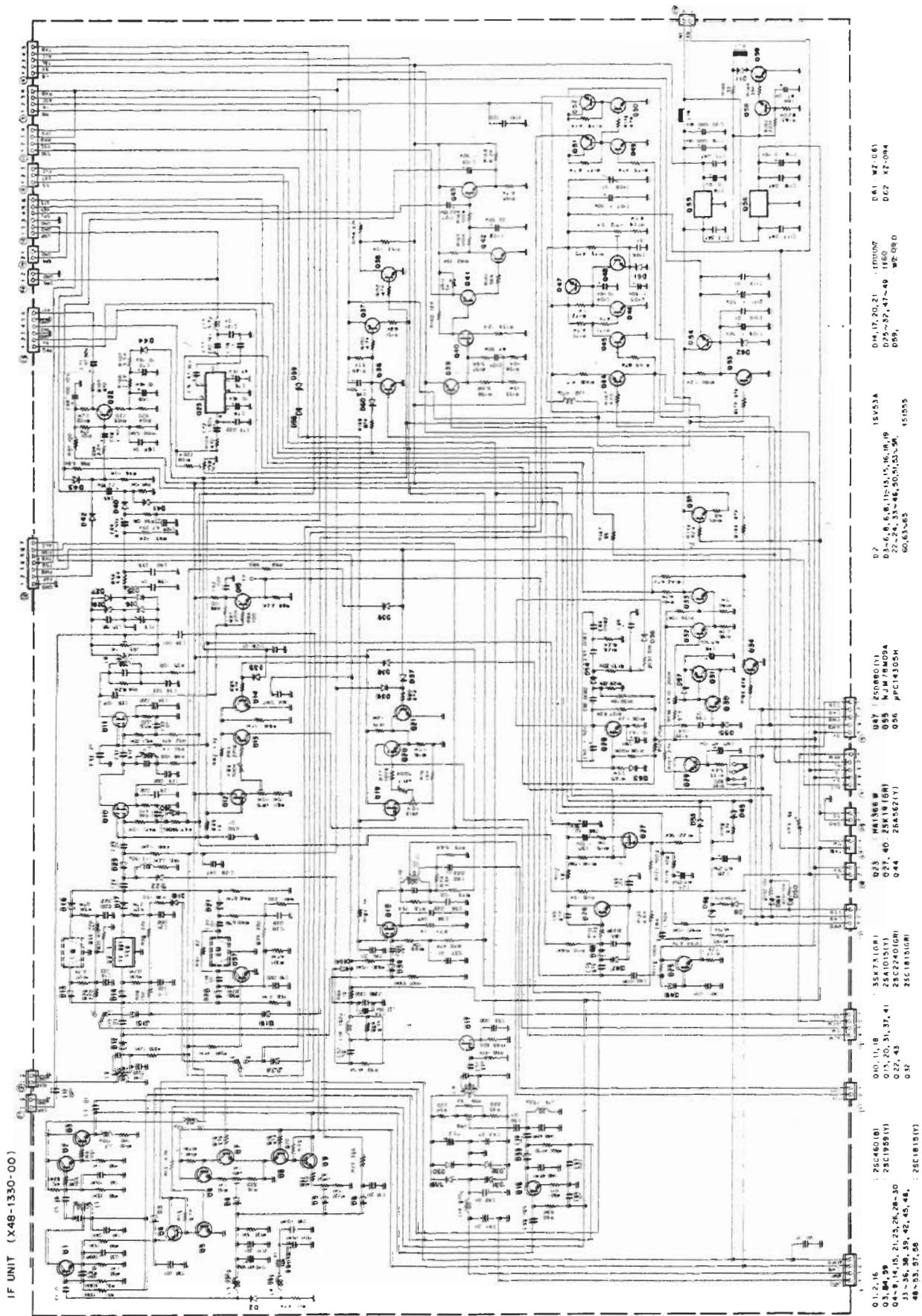

IF UNIT (X48-1330-00)

- 01-2, 16 : 25C460(B)
- 03, 84, 90 : 25C195(1)
- 05, 20, 31, 37, 41 : 25C195(1)
- 022, 43 : 25C224(1GH)
- 03 : 25C1810(1GH)
- 04, 17, 20, 21 : 15V53A
- 025-37, 47-49 : 15V53A
- 059, : 15V53A
- 061, WZ 0.61 : 15V53A
- 062, XZ 0.64 : 15V53A
- 063, : 15V53A
- 064, : 15V53A
- 065, : 15V53A
- 066, : 15V53A
- 067, : 15V53A
- 068, : 15V53A
- 069, : 15V53A
- 070, : 15V53A
- 071, : 15V53A
- 072, : 15V53A
- 073, : 15V53A
- 074, : 15V53A
- 075, : 15V53A
- 076, : 15V53A
- 077, : 15V53A
- 078, : 15V53A
- 079, : 15V53A
- 080, : 15V53A
- 081, : 15V53A
- 082, : 15V53A
- 083, : 15V53A
- 084, : 15V53A
- 085, : 15V53A
- 086, : 15V53A
- 087, : 15V53A
- 088, : 15V53A
- 089, : 15V53A
- 090, : 15V53A
- 091, : 15V53A
- 092, : 15V53A
- 093, : 15V53A
- 094, : 15V53A
- 095, : 15V53A
- 096, : 15V53A
- 097, : 15V53A
- 098, : 15V53A
- 099, : 15V53A
- 100, : 15V53A

PLL UNIT (X50-1740-00)

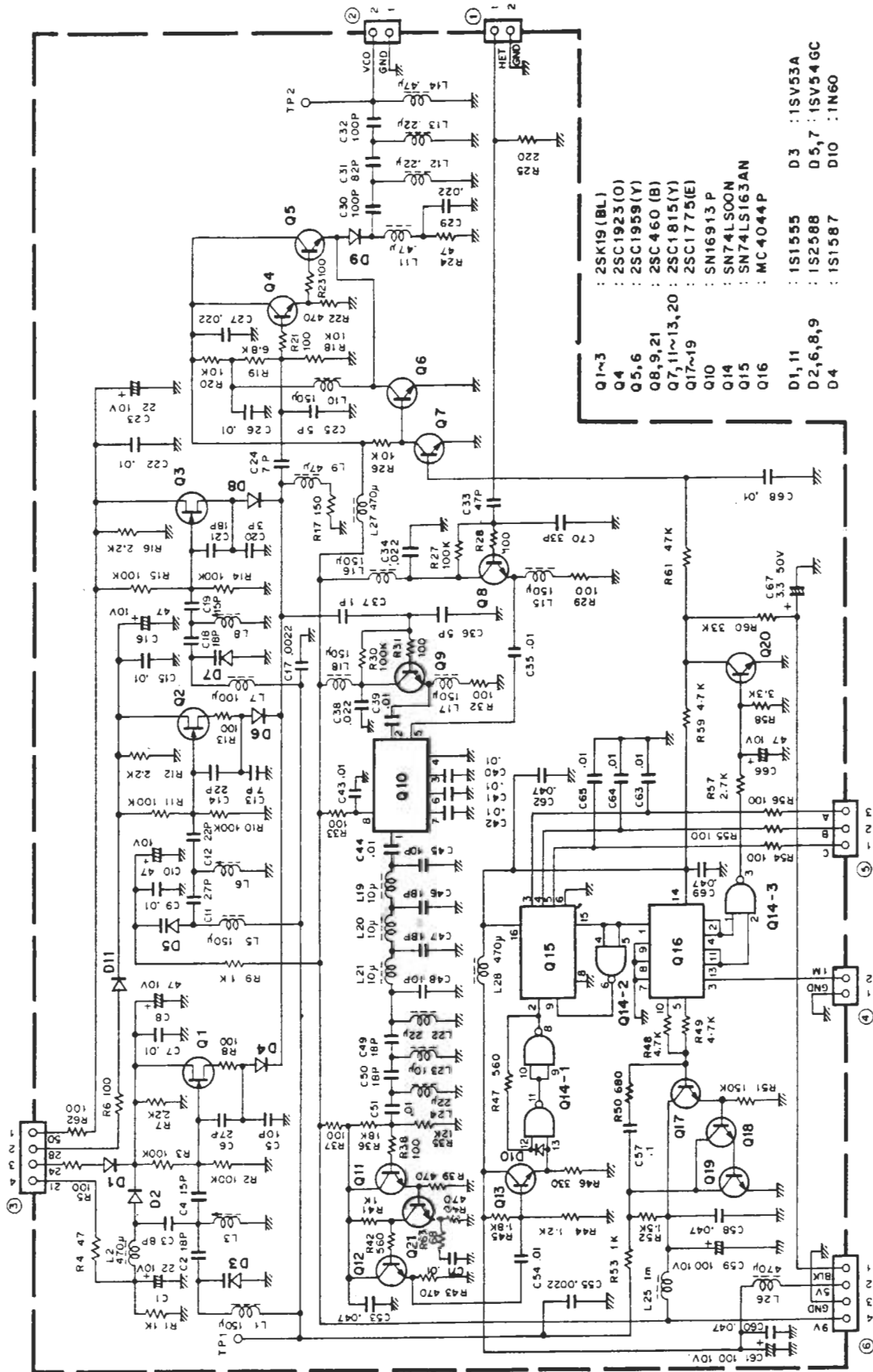

DISPLAY UNIT (X54-1630-00)

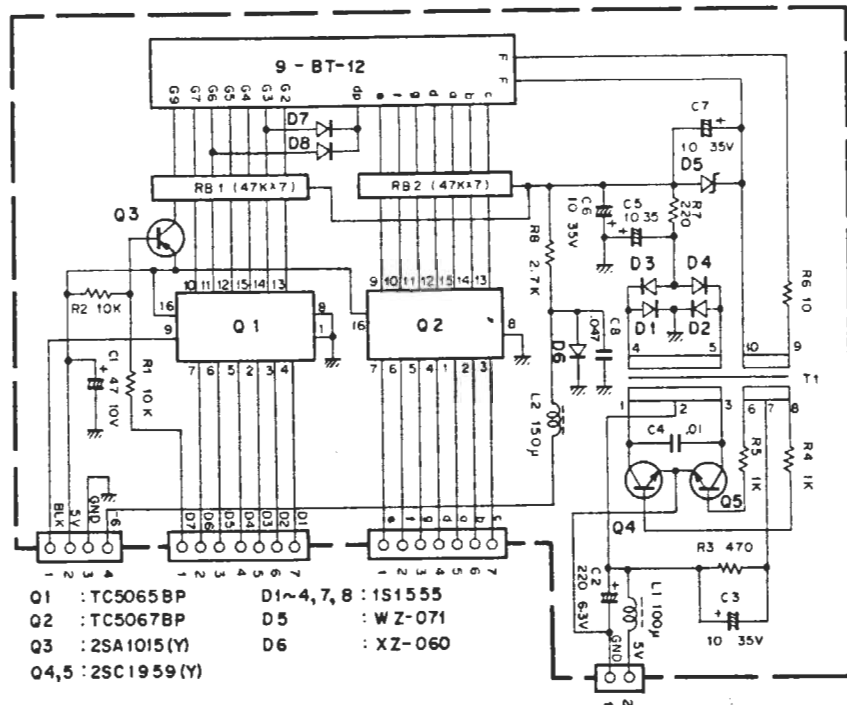

FM UNIT (X48-1340-00)

